

2018 FULL LINE CATALOG



Stomp Boxes

Ukuleles

Nylon String Guitars

Acoustic Basses

Banjos

Mandolins

Percussion

Accessories



HANDCRAFTED QUALITY

INNOVATIVE, CREATIVE & DIFFERENT



Index	Page
Stomp Boxes	004
Stomp Box Effect Series	006
Ukuleles & Guitarleles	010
Bonfire Series	016
Earth Series	019
Pineapple Series	024
Friends Series	025
Ebony Series	027
Tiger Series	028
Horizon Series	030
Lizard Series	032
Acacia Series	034
Root Series	035
Eclipse Series	036
Raven Series	037
Bonfire Series - Guitarleles	039
Tiger Series - Guitarleles	041
Nylon String Guitars	042
Student Series	044
Family Series	048
Family Series Pro	062
Feel Series	068
Traveler Series	076
Traditional Series	078
Custom Master Selection Series	082
Signature Series	086
Stage Series	090
★ The Private Room	092
Distressed Suites	094
Eclipse Suite	095
Striped Suites	096
Honey Suites	097
Acoustic Basses	098
Lizard Series	102
Deep Traveler Series	104
Deep Series 5	105
Deep Series 3	106
Deep Series 2	107
Signature Series	108
Banjos	112
Raven Series	114
Falcon Series	117
Mandolins	120
A-Style Series	122
F-Style Series	124
Percussion	126
Percussion Series	128
Stomp Box Effect Series	130
Accessories	134
Tuners	136
Cables & Power	138
Capos	140
Humidifiers & Care	141
Care & Cleaning	142
Useful Helpers	143
Tuning Machines	144
Strings	145
Picks & Strap Locks	146
Straps	148
Bags & Cases	150
Stands & Hangers	154
Apparel & Merchandise, POS	156

EXPERIENCE SINCE 1994

Established in 1994, Ortega Guitars introduced German design to authentic and traditional methods of guitar making. Committed to innovation and quality, we strive to improve what is expected at every level of all our acoustic instruments. Options like the 12hole bridge, often found only on high-end guitars, are standard at our entry level to professional nylon string guitars. Our wide variety of body and neck sizes accommodates all ages giving everyone an opportunity to learn and play. Inspection standards are placed at many stages to assure that our instruments are the finest quality before they reach your hands.



STOMP BOXES

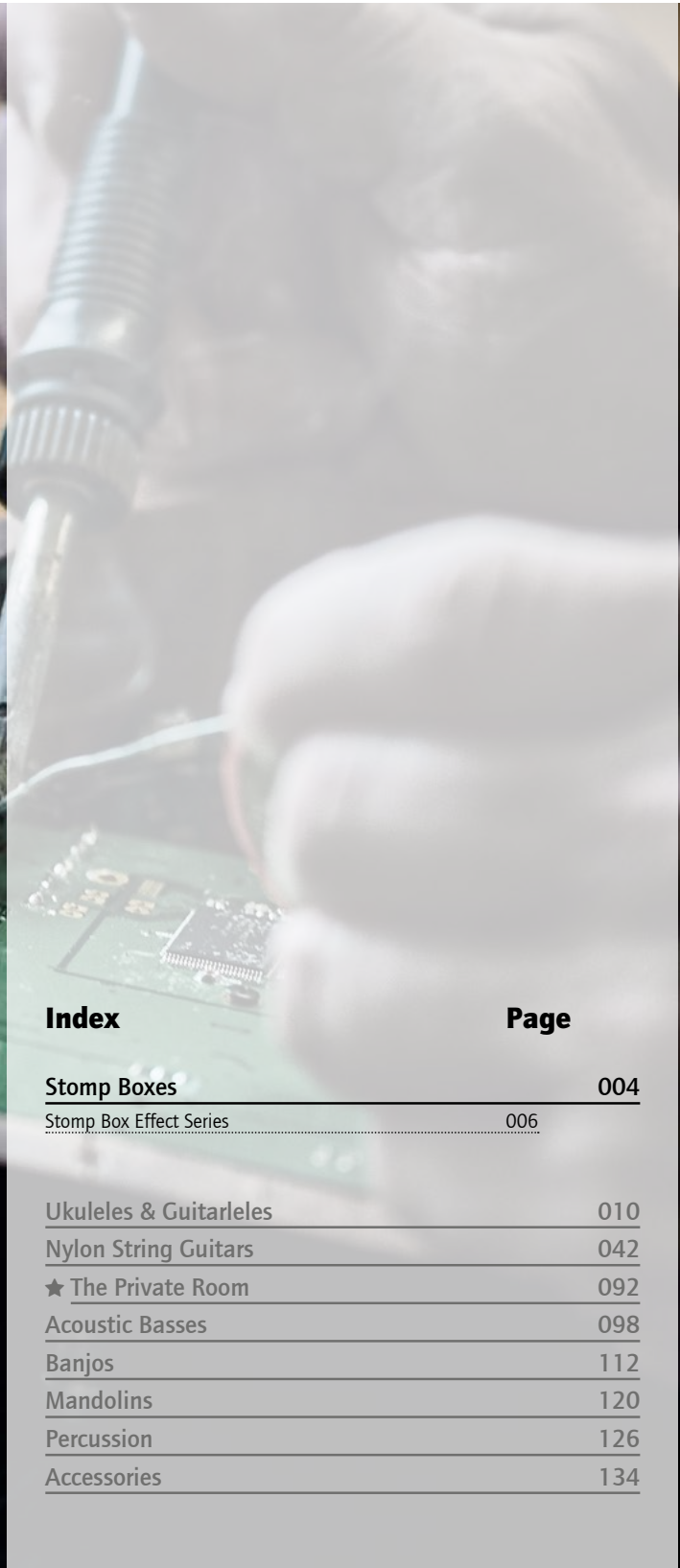

Index

Page

Stomp Boxes	004
Stomp Box Effect Series	006
Ukuleles & Guitarleles	010
Nylon String Guitars	042
★ The Private Room	092
Acoustic Basses	098
Banjos	112
Mandolins	120
Percussion	126
Accessories	134



STOMP BOX EFFECT SERIES

ORTEGA QUANTUMloop - MULTI DIGITAL PERCUSSION STOMP BOX & LOOPER

Choose between **16 DIFFERENT** BUILT-IN DRUM & PERCUSSION SAMPLED SOUNDS...

... PLUS ADD 4 CUSTOM SAMPLES (2 PER BANK) VIA USB.

20 AVAILABLE SAMPLED SOUNDS!

FREE ONLINE DOWNLOAD for sound import software (Mac & Windows)

BANK A		BANK B	
DRY KICK DRUM	SLAP CAJON	BALLAD SNARE	FINGER SNIP
FAT KICK DRUM	DOUMBK SLAP	SOUL SNARE	SHORT SHAKE
SWEET KICK DRUM	COWBELL	THE RIM	TAMBOURINE
80'S ELECTRO	PERSONAL 1	FOOT HIHAT	PERSONAL 1
DEEP CAJON	PERSONAL 2	THE CLAP	PERSONAL 2

QUANTUMloop

BUILT-IN LOOPER for instrument & sound banks

DIGITAL STOMP BOX & LOOPER with 16 built-in drum & percussion samples!

- 16 pre-installed sounds
- 4 empty slots for custom samples
- Built-in looper with unlimited numbers of overdubs
- Loop length: Up to 5 minutes
- Software for uploads & erase (free online download) - Mac & Windows
- Comfortable ergonomic design
- Solid mahogany wood housing
- Non-slip bottom coating & foot rest
- Bypass mode: True bypass
- IN & OUT 6.3 mm (1/4") jack - true discrete pass-through



CHANGE BETWEEN SOUNDS ON THE FLY. WITH 20 SAMPLES AND A LOOPER, YOUR POSSIBILITIES ARE ENDLESS.



- Removable foot rest (hook & loop)



- Trigger input, instrument in and seamless looper volume control



- Seamless volume control, Dynamic (velocity sensitivity) ON/OFF, instrument out (a true discrete pass-through) & USB port for sound import



QUANTUMexp

For maximum performance add the **QUANTUMexp** to your setup. Once connected with the QUANTUMloop via "trigger input" the sounds of BANK B are under the control of QUANTUMexp.

The QUANTUMexp operates "active" and includes a 9V battery.



FREE POWER SUPPLY included!

- FREE 9V certified quality power supply included



STOMP BOX EFFECT SERIES



ORTEGA ANALOG STOMP BOX - PERFECT FOR PLAYERS ON THE GO & STREET PERFORMERS

The Ortega **ANNAlog** analog percussion stomp box is the perfect tool for guitarists, singer/songwriters and street performers wanting to add a percussive element to any performance. With it's analog design, no battery or power supply needed. Plug-In and ready. Detailed inner construction minimizes surrounding noise to maximize bass punch. Equipped with an input and output, our discrete pass through allows you to blend the percussive sound with your instrument signal to a single channel.



ANNAlog

ANALOG STOMP BOX with built-in sound optimized piezo technology.

- **No battery or power supply needed!**
- **Input & output - only one channel needed!**
- Comfortable ergonomic design for foot tapping
- Solid cherry wood housing
- Non-slip bottom coating
- Minimized surrounding noise
- Maximized bass punch
- Seamless volume control to adjust the level of bass punch (blend the percussion sound with the unaffected instrument signal together through the output to one channel)
- 6.3 mm (1/4") input jack (connect your guitar, bass or any other stringed instrument with a true discrete pass-through to output)
- 6.3 mm (1/4") output jack (connect to amp or sound system)

NO BATTERY
or
POWER SUPPLY
needed!

Your HANDS FREE
rhythm section
for take-out!

ORTEGA DIGITAL STOMP BOXES - PERFECT FOR SINGER/SONGWriters ON THE GO OR IN THE STUDIO

The Ortega **HORSE KICK V2** & **HORSE KICK PRO** digital stomp boxes are great tools for guitarists, singers, songwriters and street performers wanting to add a percussive element to any performance. With digital samples of real percussion sounds the HORSE KICK Stomp Boxes are way ahead of any existing analog/acoustic stomp boxes eliminating feedback and the surrounding noises. Just connect your favorite HORSE KICK to any amplifier or sound system and enhance your solo performance.

HORSE KICK V2

DIGITAL STOMP BOX with built-in digitally sampled "Cajon Bass" sound!

- Digital sample of a "Cajon Bass" sound - just tap your foot
 - Comfortable ergonomic design for foot tapping
 - Solid ash wood housing
 - Non-slip bottom coating
 - Velocity sensitive for an expressive experience
 - Seamless volume control to adjust percussion sound
 - 6.3 mm (1/4") input jack (connect your guitar, bass or any other stringed instrument with a true discrete pass-through to output)
 - 6.3 mm (1/4") output jack (connect to amp or sound system)
 - Powered by power supply
- FREE 9V certified quality power supply included**



Your **HANDS FREE** rhythm section for take-out!

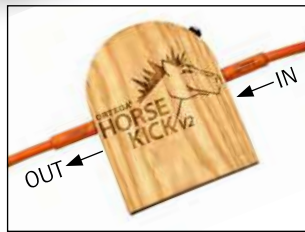

HORSE KICK PRO

DIGITAL STOMP BOX with multiple built-in digital samples of percussion sounds that can be played on its own, as a percussive instrument, or blended with your stringed instrument signal through the output.

- Digital samples of percussion instruments - just choose between 5 different percussion samples and tap your foot
- Comfortable ergonomic design for foot tapping
- Solid sapele (mahogany) wood housing
- Non-slip bottom coating
- Velocity sensitive for an expressive experience
- Seamless volume control to adjust percussion sounds (blend the percussion sound with the unaffected instrument signal together through the output to one channel)
- 6.3 mm (1/4") input jack (connect your guitar, bass or any other stringed instrument with a true discrete pass-through to output)
- 6.3 mm (1/4") output jack (connect to amp or sound system)
- Powered by 9V battery or power supply

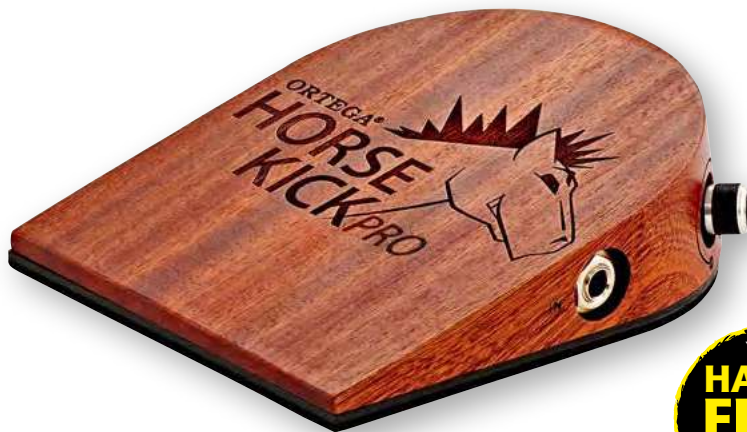

Your **HANDS FREE** rhythm section for take-out!

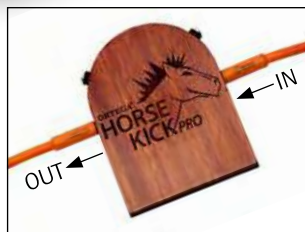

Choose between **5 DIFFERENT PERCUSSION SAMPLES:**

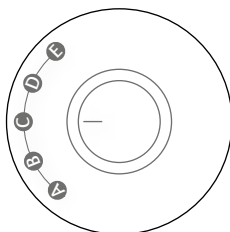
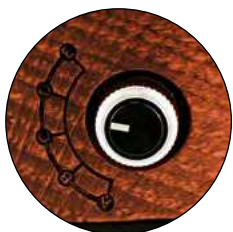

- E: Tambourine
- D: Cabasa
- C: Cowbell
- B: Kick Drum
- A: Cajon Bass

FREE 9V certified quality power supply included

FREE 9V battery already packed for you



UKULELES & GUITARLELES





Index

Page

Stomp Boxes	004
<hr/>	
Ukuleles & Guitarleles	010
Bonfire Series	016
Earth Series	019
Pineapple Series	024
Friends Series	025
Ebony Series	027
Tiger Series	028
Horizon Series	030
Lizard Series	032
Acacia Series	034
Root Series	035
Eclipse Series	036
Raven Series	037
Bonfire Series – Guitarleles	039
Tiger Series – Guitarleles	041
<hr/>	
Nylon String Guitars	042
★ The Private Room	092
Acoustic Basses	098
Banjos	112
Mandolins	120
Percussion	126
Accessories	134



**BONFIRE
EARTH
PINEAPPLE
FRIENDS
EBONY
TIGER
HORIZON
LIZARD
ACACIA
ROOT
ECLIPSE
RAVEN**

Whether you're playing for fun or performing professionally. Ortega offers a broad range and levels of traditional Soprano, Concert, Tenor and Baritone body sizes. Select models are equipped with our own preamp and built-in tuner.

SERIES







ALL SERIES

YOUR OPTIONS

scales and sizes

width at nut

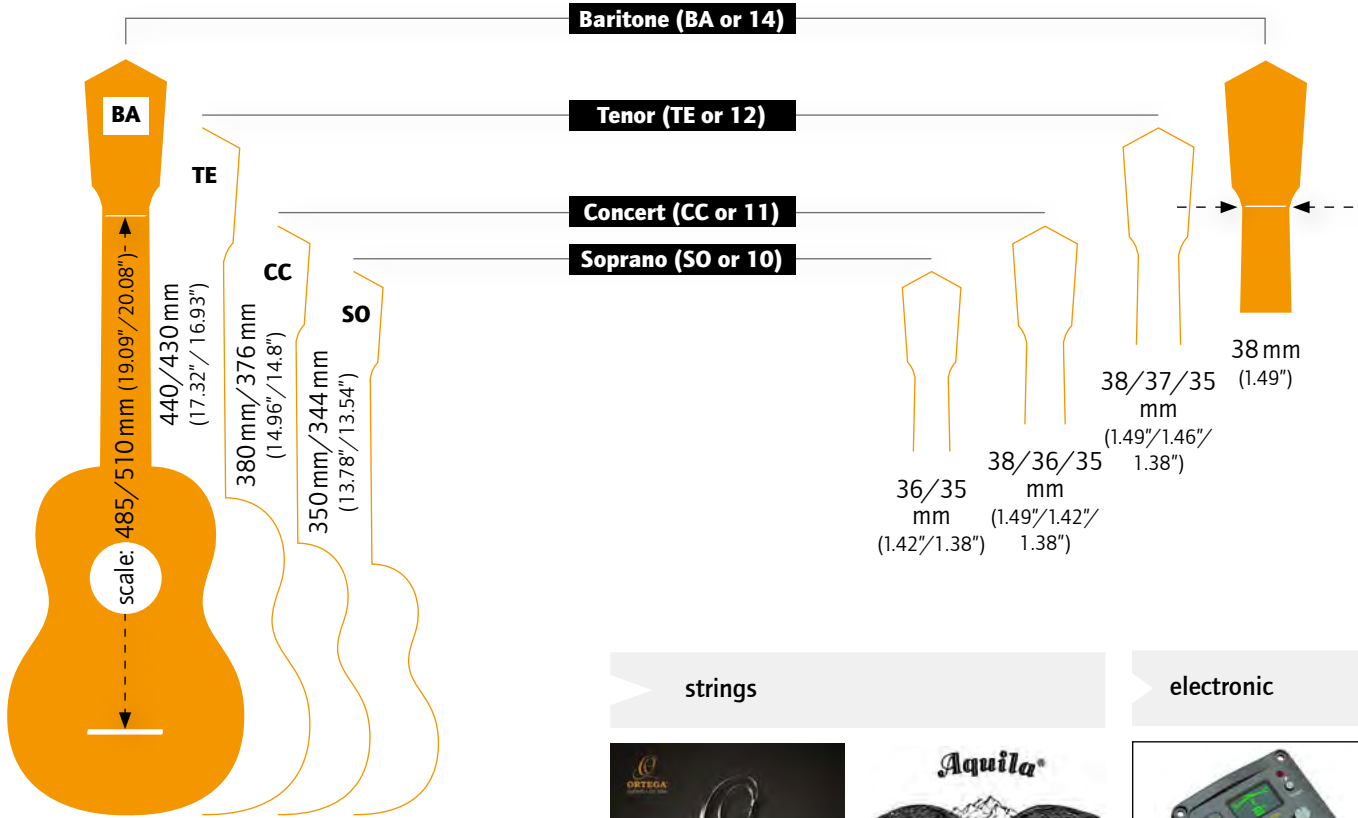

strings

electronic



Aquila New Nylgut 6string/8string tenor



Preamp with built-in tuner



All ukulele preamps are powered with CR2032 coin cell batteries (see page 136).

features

body

Ortega Guitars soprano UWNY-4-SO/
concert UWNY-4-CC/
tenor UWNY-4-TE/
baritone strings UWNY-4-BA
(see page 145)

bag



non cutaway



cutaway

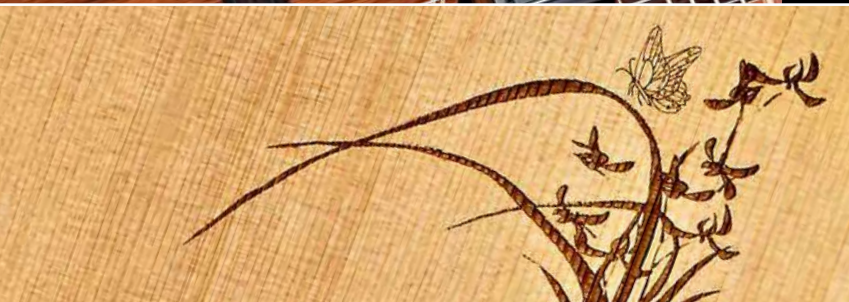

wood variations:
back & sides

wood variations: top



solid mahogany

flamed mahogany

sapele



spruce

solid mahogany

flamed mahogany

sapele

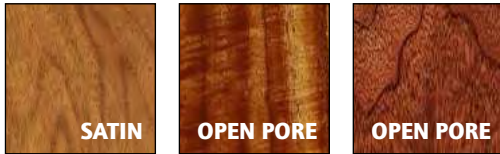

paldao (dao)

acacia

walnut



zebrawood

paldao (dao)

acacia

walnut



zebrawood

okoume

okoume



okoume

okoume

okoume

okoume



okoume

okoume

okoume



okoume

mango

bamboo

ebony

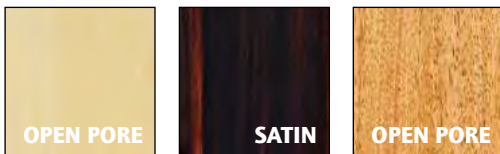

bamboo

ebony

mango





BONFIRE SERIES SPRUCE TOP

RU5-S0



Soprano scale: 350 mm (13.78")
width at nut: 36 mm (1.42")

- Spruce top, satin finish, laser engraved
- Sapele back & side, satin finish
- Mahogany neck, satin finish
- Tortoise style ABS binding
- Walnut fretboard & bridge
- Die cast tuning machines, chrome
- Ortega Guitars soprano UWNY-4-S0 strings

RU5CE-S0



CUTAWAY/PICKUP



Soprano scale: 350 mm (13.78")
width at nut: 36 mm (1.42")

- Spruce top, satin finish, laser engraved
- Sapele back & side, satin finish
- Mahogany neck, satin finish
- Tortoise style ABS binding
- Walnut fretboard & bridge
- Ortega MagusUke preamp/pickup system
- Die cast tuning machines, chrome
- Ortega Guitars soprano UWNY-4-S0 strings

RU5



Concert scale: 380 mm (14.96")
width at nut: 36 mm (1.42")

- Spruce top, satin finish, laser engraved
- Sapele back & side, satin finish
- Mahogany neck, satin finish
- Tortoise style ABS binding
- Walnut fretboard & bridge
- Die cast tuning machines, chrome
- Ortega Guitars concert UWNY-4-CC strings

RU5CE



CUTAWAY/PICKUP



Concert scale: 380 mm (14.96")
width at nut: 36 mm (1.42")

- Spruce top, satin finish, laser engraved
- Sapele back & side, satin finish
- Mahogany neck, satin finish
- Tortoise style ABS binding
- Walnut fretboard & bridge
- Ortega MagusUke preamp/pickup system
- Die cast tuning machines, chrome
- Ortega Guitars concert UWNY-4-CC strings



Tenor

scale: 440 mm (17.32")
width at nut: 37 mm (1.45")

RU5-TE

- Spruce top, satin finish, laser engraved
- Sapele back & side, satin finish
- Mahogany neck, satin finish
- Tortoise style ABS binding
- Walnut fretboard & bridge
- Die cast tuning machines, chrome
- Ortega Guitars tenor UWNY-4-TE strings



CUTAWAY/PICKUP

Tenor

scale: 440 mm (17.32")
width at nut: 37 mm (1.45")



RUSCE-TE

- Spruce top, satin finish, laser engraved
- Sapele back & side, satin finish
- Mahogany neck, satin finish
- Tortoise style ABS binding
- Walnut fretboard & bridge
- Ortega MagusUke preamp/pickup system
- Die cast tuning machines, chrome
- Ortega Guitars tenor UWNY-4-TE strings



Baritone

scale: 485 mm (19.09")
width at nut: 38 mm (1.49")

RU5-BA

- Spruce top, satin finish, laser engraved
- Sapele back & side, satin finish
- Mahogany neck, satin finish
- Tortoise style ABS binding
- Walnut fretboard & bridge
- Die cast tuning machines, chrome
- Ortega Guitars baritone UWNY-4-BA strings



CUTAWAY/PICKUP

Baritone

scale: 485 mm (19.09")
width at nut: 38 mm (1.49")



RUSCE-BA

- Spruce top, satin finish, laser engraved
- Sapele back & side, satin finish
- Mahogany neck, satin finish
- Tortoise style ABS binding
- Walnut fretboard & bridge
- Ortega MagusUke preamp/pickup system
- Die cast tuning machines, chrome
- Ortega Guitars baritone UWNY-4-BA strings



BONFIRE SERIES SAPELE TOP



Soprano scale: 350 mm (13.78")
width at nut: 36 mm (1.42")

RU5MM-SO

- Sapele top, satin finish, laser engraved
- Sapele back & side, satin finish
- Mahogany neck, satin finish
- Tortoise style ABS binding
- Walnut fretboard & bridge
- Die cast tuning machines, chrome
- Ortega Guitars soprano UWNY-4-SO strings



Concert scale: 380 mm (14.96")
width at nut: 36 mm (1.42")

RU5MM

- Sapele top, satin finish, laser engraved
- Sapele back & side, satin finish
- Mahogany neck, satin finish
- Tortoise style ABS binding
- Walnut fretboard & bridge
- Die cast tuning machines, chrome
- Ortega Guitars concert UWNY-4-CC strings



Tenor scale: 440 mm (17.32")
width at nut: 37 mm (1.45")

RU5MM-TE

- Sapele top, satin finish, laser engraved
- Sapele back & side, satin finish
- Mahogany neck, satin finish
- Tortoise style ABS binding
- Walnut fretboard & bridge
- Die cast tuning machines, chrome
- Ortega Guitars tenor UWNY-4-TE strings



Baritone scale: 485 mm (19.09")
width at nut: 38 mm (1.49")

RU5MM-BA

- Sapele top, satin finish, laser engraved
- Sapele back & side, satin finish
- Mahogany neck, satin finish
- Tortoise style ABS binding
- Walnut fretboard & bridge
- Die cast tuning machines, chrome
- Ortega Guitars baritone UWNY-4-BA strings



Concert scale: 380 mm (14.96")
width at nut: 36 mm (1.42")

FOREST
forest green

RUFOREST

- Okoume top, forest green satin finish
- Okoume back & side, forest green satin finish
- Mahogany neck, forest green satin finish
- White ABS binding
- Walnut fretboard & bridge
- Die cast tuning machines, chrome
- Ortega Guitars concert UWNY-4-CC strings



CUTAWAY/PICKUP



Concert scale: 380 mm (14.96")
width at nut: 36 mm (1.42")

FOREST
forest green

RUFOREST-CE

- Okoume top, forest green satin finish
- Okoume back & side, forest green satin finish
- Mahogany neck, forest green satin finish
- White ABS binding
- Walnut fretboard & bridge
- Ortega MagusUke preamp/pickup system
- Die cast tuning machines, chrome
- Ortega Guitars concert UWNY-4-CC strings



Concert scale: 380 mm (14.96")
width at nut: 36 mm (1.42")

OCEAN
ocean blue

RUOCEAN

- Okoume top, ocean blue satin finish
- Okoume back & side, ocean blue satin finish
- Mahogany neck, ocean blue satin finish
- White ABS binding
- Walnut fretboard & bridge
- Die cast tuning machines, chrome
- Ortega Guitars concert UWNY-4-CC strings



CUTAWAY/PICKUP



Concert scale: 380 mm (14.96")
width at nut: 36 mm (1.42")

OCEAN
ocean blue

RUOCEAN-CE

- Okoume top, ocean blue satin finish
- Okoume back & side, ocean blue satin finish
- Mahogany neck, ocean blue satin finish
- White ABS binding
- Walnut fretboard & bridge
- Ortega MagusUke preamp/pickup system
- Die cast tuning machines, chrome
- Ortega Guitars concert UWNY-4-CC strings



EARTH SERIES OKOUME TOP

RUFIRE



Concert scale: 380 mm (14.96")
width at nut: 36 mm (1.42") **FIRE**
fire red

- Okoume top, fire red satin finish
- Okoume back & side, fire red satin finish
- Mahogany neck, fire red satin finish
- White ABS binding
- Walnut fretboard & bridge
- Die cast tuning machines, chrome
- Ortega Guitars concert UWNY-4-CC strings

RUFIRE-CE



CUTAWAY/PICKUP



Concert scale: 380 mm (14.96")
width at nut: 36 mm (1.42") **FIRE**
fire red

- Okoume top, fire red satin finish
- Okoume back & side, fire red satin finish
- Mahogany neck, fire red satin finish
- White ABS binding
- Walnut fretboard & bridge
- Ortega MagusUke preamp/pickup system
- Die cast tuning machines, chrome
- Ortega Guitars concert UWNY-4-CC strings

RUCOAL



Concert scale: 380 mm (14.96")
width at nut: 36 mm (1.42") **COAL**
coal black

- Okoume top, coal black satin finish
- Okoume back & side, coal black satin finish
- Mahogany neck, coal black satin finish
- White ABS binding
- Walnut fretboard & bridge
- Die cast tuning machines, chrome
- Ortega Guitars concert UWNY-4-CC strings

RUCOAL-CE



CUTAWAY/PICKUP



Concert scale: 380 mm (14.96")
width at nut: 36 mm (1.42") **COAL**
coal black

- Okoume top, coal black satin finish
- Okoume back & side, coal black satin finish
- Mahogany neck, coal black satin finish
- White ABS binding
- Walnut fretboard & bridge
- Ortega MagusUke preamp/pickup system
- Die cast tuning machines, chrome
- Ortega Guitars concert UWNY-4-CC strings



Concert scale: 380 mm (14.96")
width at nut: 36 mm (1.42")

DAWN
dawn sunburst

RUDAWN

- Okoume top, dawn sunburst satin finish
- Okoume back & side, dawn sunburst satin finish
- Mahogany neck, dawn sunburst satin finish
- White ABS binding
- Walnut fretboard & bridge
- Die cast tuning machines, chrome
- Ortega Guitars concert UWNY-4-CC strings



CUTAWAY/PICKUP



Concert scale: 380 mm (14.96")
width at nut: 36 mm (1.42")

DAWN
dawn sunburst

RUDAWN-CE

- Okoume top, dawn sunburst satin finish
- Okoume back & side, dawn sunburst satin finish
- Mahogany neck, dawn sunburst satin finish
- White ABS binding
- Walnut fretboard & bridge
- Ortega MagusUke preamp/pickup system
- Die cast tuning machines, chrome
- Ortega Guitars concert UWNY-4-CC strings



Concert scale: 380 mm (14.96")
width at nut: 36 mm (1.42")

RUBY
ruby raspberry

RURUBY

- Okoume top, ruby raspberry satin finish
- Okoume back & side, ruby raspberry satin finish
- Mahogany neck, ruby raspberry satin finish
- White ABS binding
- Walnut fretboard & bridge
- Die cast tuning machines, chrome
- Ortega Guitars concert UWNY-4-CC strings



CUTAWAY/PICKUP



Concert scale: 380 mm (14.96")
width at nut: 36 mm (1.42")

RUBY
ruby raspberry

RURUBY-CE

- Okoume top, ruby raspberry satin finish
- Okoume back & side, ruby raspberry satin finish
- Mahogany neck, ruby raspberry satin finish
- White ABS binding
- Walnut fretboard & bridge
- Ortega MagusUke preamp/pickup system
- Die cast tuning machines, chrome
- Ortega Guitars concert UWNY-4-CC strings



EARTH SERIES OKOUME TOP

RUGOLD



Concert scale: 380 mm (14.96") width at nut: 36 mm (1.42") **GOLD**
gold

- Okoume top, gold satin finish
- Okoume back & side, gold satin finish
- Mahogany neck, gold satin finish
- White ABS binding
- Walnut fretboard & bridge
- Die cast tuning machines, chrome
- Ortega Guitars concert UWNY-4-CC strings

RUGOLD-CE



CUTAWAY/PICKUP



Concert scale: 380 mm (14.96") width at nut: 36 mm (1.42") **GOLD**
gold

- Okoume top, gold satin finish
- Okoume back & side, gold satin finish
- Mahogany neck, gold satin finish
- White ABS binding
- Walnut fretboard & bridge
- Ortega MagusUke preamp/pickup system
- Die cast tuning machines, chrome
- Ortega Guitars concert UWNY-4-CC strings

RUSILVER



Concert scale: 380 mm (14.96") width at nut: 36 mm (1.42") **SILVER**
silver

- Okoume top, silver satin finish
- Okoume back & side, silver satin finish
- Mahogany neck, silver satin finish
- White ABS binding
- Walnut fretboard & bridge
- Die cast tuning machines, chrome
- Ortega Guitars concert UWNY-4-CC strings

RUSILVER-CE



CUTAWAY/PICKUP



Concert scale: 380 mm (14.96") width at nut: 36 mm (1.42") **SILVER**
silver

- Okoume top, silver satin finish
- Okoume back & side, silver satin finish
- Mahogany neck, silver satin finish
- White ABS binding
- Walnut fretboard & bridge
- Ortega MagusUke preamp/pickup system
- Die cast tuning machines, chrome
- Ortega Guitars concert UWNY-4-CC strings

RULAGOON



Concert scale: 380 mm (14.96")
width at nut: 36 mm (1.42")

LAGOON
lagoon turquoise

- Okoume top, lagoon turquoise satin finish
- Okoume back & side, lagoon turquoise satin finish
- Mahogany neck, lagoon turquoise satin finish
- White ABS binding
- Walnut fretboard & bridge
- Die cast tuning machines, chrome
- Ortega Guitars concert UWNY-4-CC strings

RULAGOON-CE



CUTAWAY/PICKUP



Concert scale: 380 mm (14.96")
width at nut: 36 mm (1.42")

LAGOON
lagoon turquoise

- Okoume top, lagoon turquoise satin finish
- Okoume back & side, lagoon turquoise satin finish
- Mahogany neck, lagoon turquoise satin finish
- White ABS binding
- Walnut fretboard & bridge
- Ortega MagusUke preamp/pickup system
- Die cast tuning machines, chrome
- Ortega Guitars concert UWNY-4-CC strings

RUSUN



Concert scale: 380 mm (14.96")
width at nut: 36 mm (1.42")

SUN
sun yellow

- Okoume top, sun yellow satin finish
- Okoume back & side, sun yellow satin finish
- Mahogany neck, sun yellow satin finish
- White ABS binding
- Walnut fretboard & bridge
- Die cast tuning machines, chrome
- Ortega Guitars concert UWNY-4-CC strings

RUSUN-CE



CUTAWAY/PICKUP



Concert scale: 380 mm (14.96")
width at nut: 36 mm (1.42")

SUN
sun yellow

- Okoume top, sun yellow satin finish
- Okoume back & side, sun yellow satin finish
- Mahogany neck, sun yellow satin finish
- White ABS binding
- Walnut fretboard & bridge
- Ortega MagusUke preamp/pickup system
- Die cast tuning machines, chrome
- Ortega Guitars concert UWNY-4-CC strings



PINEAPPLE SERIES



PINEAPPLE STYLE

scale: 380 mm (14.96")
width at nut: 36 mm (1.42")

RUPA5

- Spruce top, satin finish, laser engraved palm trees
- Sapele back & side, satin finish
- Mahogany neck, satin finish
- Tortoise style ABS binding
- Walnut fretboard & bridge
- Die cast tuning machines, chrome
- Ortega Guitars concert UWNY-4-CC strings



PINEAPPLE STYLE

scale: 380 mm (14.96")
width at nut: 36 mm (1.42")

RUPA5MM

- Sapele top, satin finish, laser engraved palm trees
- Sapele back & side, satin finish
- Mahogany neck, satin finish
- Tortoise style ABS binding
- Walnut fretboard & bridge
- Die cast tuning machines, chrome
- Ortega Guitars concert UWNY-4-CC strings



PINEAPPLE STYLE/PICKUP

scale: 380 mm (14.96")
width at nut: 36 mm (1.42")

RUPA5MM-E

- Sapele top, satin finish, laser engraved palm trees
- Sapele back & side, satin finish
- Mahogany neck, satin finish
- Tortoise style ABS binding
- Walnut fretboard & bridge
- Die cast tuning machines, chrome
- Active Soundhole preamp/pickup
- Strap pin connector
- Ortega Guitars concert UWNY-4-CC strings





Soprano scale: 350 mm (13.78")
width at nut: 36 mm (1.42")

RFU10S



- Sapele top, satin finish
- Sapele back & side, satin finish
- Mahogany neck, satin finish
- Walnut fretboard & bridge
- Die cast tuning machines, chrome
- Ortega Guitars soprano UWNY-4-SO strings
- FREE deluxe gig bag included



PICKUP

Soprano scale: 350 mm (13.78")
width at nut: 36 mm (1.42")



RFU10SE



- Sapele top, satin finish
- Sapele back & side, satin finish
- Mahogany neck, satin finish
- Walnut fretboard & bridge
- Ortega MagusUke preamp/pickup system
- Die cast tuning machines, chrome
- Ortega Guitars soprano UWNY-4-SO strings
- FREE deluxe gig bag included



Concert scale: 380 mm (14.96")
width at nut: 36 mm (1.42")

RFU11S



- Sapele top, satin finish
- Sapele back & side, satin finish
- Mahogany neck, satin finish
- Walnut fretboard & bridge
- Die cast tuning machines, chrome
- Ortega Guitars concert UWNY-4-CC strings
- FREE deluxe gig bag included



PICKUP

Concert scale: 380 mm (14.96")
width at nut: 36 mm (1.42")



RFU11SE



- Sapele top, satin finish
- Sapele back & side, satin finish
- Mahogany neck, satin finish
- Walnut fretboard & bridge
- Ortega MagusUke preamp/pickup system
- Die cast tuning machines, chrome
- Ortega Guitars concert UWNY-4-CC strings
- FREE deluxe gig bag included



FRIENDS SERIES ZEBRAWOOD



Soprano scale: 350 mm (13.78")
width at nut: 36 mm (1.42")

RFU10Z



- Zebrawood top, satin finish
- Zebrawood back & side, satin finish
- Mahogany neck, satin finish
- Walnut fretboard & bridge
- Die cast tuning machines, chrome
- Ortega Guitars soprano UWNY-4-SO strings
- FREE deluxe gig bag included



PICKUP

Soprano scale: 350 mm (13.78")
width at nut: 36 mm (1.42")



RFU10ZE



- Zebrawood top, satin finish
- Zebrawood back & side, satin finish
- Mahogany neck, satin finish
- Walnut fretboard & bridge
- Ortega MagusUke preamp/pickup system
- Die cast tuning machines, chrome
- Ortega Guitars soprano UWNY-4-SO strings
- FREE deluxe gig bag included



Concert scale: 380 mm (14.96")
width at nut: 36 mm (1.42")

RFU11Z



- Zebrawood top, satin finish
- Zebrawood back & side, satin finish
- Mahogany neck, satin finish
- Walnut fretboard & bridge
- Die cast tuning machines, chrome
- Ortega Guitars concert UWNY-4-CC strings
- FREE deluxe gig bag included



PICKUP

Concert scale: 380 mm (14.96")
width at nut: 36 mm (1.42")



RFU11ZE



- Zebrawood top, satin finish
- Zebrawood back & side, satin finish
- Mahogany neck, satin finish
- Walnut fretboard & bridge
- Ortega MagusUke preamp/pickup system
- Die cast tuning machines, chrome
- Ortega Guitars concert UWNY-4-CC strings
- FREE deluxe gig bag included



Soprano scale: 350 mm (13.78")
width at nut: 35 mm (1.38")

RUEB-SO



- Ebony top, satin open pore finish
- Ebony back & side, satin open pore finish
- Mahogany neck, satin finish
- Tortoise style binding
- Walnut fretboard & bridge
- Tortoise style rosette
- Die cast tuning machines, gold
- Ortega Guitars soprano UWNY-4-SO strings
- FREE deluxe gig bag included



Concert scale: 380 mm (14.96")
width at nut: 36 mm (1.42")

RUEB-CC



- Ebony top, satin open pore finish
- Ebony back & side, satin open pore finish
- Mahogany neck, satin finish
- Tortoise style binding
- Walnut fretboard & bridge
- Tortoise style rosette
- Die cast tuning machines, gold
- Ortega Guitars concert UWNY-4-CC strings
- FREE deluxe gig bag included





TIGER SERIES FLAMED MAHOGANY



Soprano scale: 350 mm (13.78")
width at nut: 36 mm (1.42")

RUK10FMH

- Flamed mahogany top, gloss finish
- Flamed mahogany back & side, gloss finish
- Mahogany neck, gloss finish
- Tortoise style ABS binding
- Walnut fretboard & bridge
- Indirect tuning machines, gold
- Ortega Guitars soprano UWNY-4-50 strings
- FREE deluxe gig bag included



PICKUP

Soprano scale: 350 mm (13.78")
width at nut: 36 mm (1.42")



RUE10FMH

- Flamed mahogany top, gloss finish
- Flamed mahogany back & side, gloss finish
- Mahogany neck, gloss finish
- Tortoise style ABS binding
- Walnut fretboard & bridge
- Ortega MagusUke preamp/pickup system
- Indirect tuning machines, gold
- Ortega Guitars soprano UWNY-4-50 strings
- FREE deluxe gig bag included



Concert scale: 380 mm (14.96")
width at nut: 36 mm (1.42")

RUK11FMH

- Flamed mahogany top, gloss finish
- Flamed mahogany back & side, gloss finish
- Mahogany neck, gloss finish
- Tortoise style ABS binding
- Walnut fretboard & bridge
- Indirect tuning machines, gold
- Ortega Guitars concert UWNY-4-CC strings
- FREE deluxe gig bag included



PICKUP

Concert scale: 380 mm (14.96")
width at nut: 36 mm (1.42")



RUE11FMH

- Flamed mahogany top, gloss finish
- Flamed mahogany back & side, gloss finish
- Mahogany neck, gloss finish
- Tortoise style ABS binding
- Walnut fretboard & bridge
- Ortega MagusUke preamp/pickup system
- Indirect tuning machines, gold
- Ortega Guitars concert UWNY-4-CC strings
- FREE deluxe gig bag included



TIGER SERIES FLAMED MAHOGANY



Tenor scale: 440 mm (17.32")
width at nut: 37 mm (1.45")

RUK12FMH



- Flamed mahogany top, gloss finish
- Flamed mahogany back & side, gloss finish
- Mahogany neck, gloss finish
- Tortoise style ABS binding
- Walnut fretboard & bridge
- Indirect tuning machines, gold
- Ortega Guitars tenor UWNY-4-TE strings
- FREE deluxe gig bag included



PICKUP

Tenor scale: 440 mm (17.32")
width at nut: 37 mm (1.45")

RUE12FMH



- Flamed mahogany top, gloss finish
- Flamed mahogany back & side, gloss finish
- Mahogany neck, gloss finish
- Tortoise style ABS binding
- Walnut fretboard & bridge
- Ortega MagusUke preamp/pickup system
- Indirect tuning machines, gold
- Ortega Guitars tenor UWNY-4-TE strings
- FREE deluxe gig bag included



Baritone scale: 485 mm (19.09")
width at nut: 38 mm (1.49")

RUK14FMH



- Flamed mahogany top, gloss finish
- Flamed mahogany back & side, gloss finish
- Mahogany neck, gloss finish
- Tortoise style ABS binding
- Walnut fretboard & bridge
- Indirect tuning machines, gold
- Ortega Guitars baritone UWNY-4-BA strings
- FREE deluxe gig bag included



PICKUP

Baritone scale: 485 mm (19.09")
width at nut: 38 mm (1.49")

RUE14FMH



- Flamed mahogany top, gloss finish
- Flamed mahogany back & side, gloss finish
- Mahogany neck, gloss finish
- Tortoise style ABS binding
- Walnut fretboard & bridge
- Ortega MagusUke preamp/pickup system
- Indirect tuning machines, gold
- Ortega Guitars baritone UWNY-4-BA strings
- FREE deluxe gig bag included



HORIZON SERIES



Concert scale: 376 mm (14.80")
width at nut: 35 mm (1.38")

RUMG



- Mango top, satin open pore
- Mango back & side, satin open pore
- Reversed headstock, 4 in line
- Okoume neck, satin finish
- Walnut top, bottom & fretboard binding
- Tecwood fretboard & bridge
- Die cast tuning machines, gold w/black buttons
- Ortega Guitars concert UWNY-4-CC strings
- FREE deluxe gig bag included



CUTAWAY/PICKUP



Concert scale: 376 mm (14.80")
width at nut: 35 mm (1.38")

RUMG-CE



- Mango top, satin open pore
- Mango back & side, satin open pore
- Reversed headstock, 4 in line
- Okoume neck, satin finish
- Walnut top, bottom & fretboard binding
- Tecwood fretboard & bridge
- Ortega MagusUke preamp/pickup system
- Die cast tuning machines, gold w/black buttons
- Ortega Guitars concert UWNY-4-CC strings
- FREE deluxe gig bag included





Concert scale: 376 mm (14.80")
width at nut: 35 mm (1.38")

RUBO



- Bamboo top, satin open pore
- Bamboo back & side, satin open pore
- Reversed headstock, 4 in line
- Okoume neck, satin finish
- Walnut top, bottom & fretboard binding
- Tecwood fretboard & bridge
- Die cast tuning machines, gold w/black buttons
- Ortega Guitars concert UWNY-4-CC strings
- FREE deluxe gig bag included



CUTAWAY/PICKUP

Concert scale: 376 mm (14.80")
width at nut: 35 mm (1.38")



RUBO-CE



- Bamboo top, satin open pore
- Bamboo back & side, satin open pore
- Reversed headstock, 4 in line
- Okoume neck, satin finish
- Walnut top, bottom & fretboard binding
- Tecwood fretboard & bridge
- Ortega MagusUke preamp/pickup system
- Die cast tuning machines, gold w/black buttons
- Ortega Guitars concert UWNY-4-CC strings
- FREE deluxe gig bag included



Concert scale: 376 mm (14.80")
width at nut: 35 mm (1.38")

RUWN



- Walnut top, satin open pore
- Walnut back & side, satin open pore
- Reversed headstock, 4 in line
- Okoume neck, satin finish
- Maple top, bottom & fretboard binding
- Tecwood fretboard & bridge
- Die cast tuning machines, gold w/black buttons
- Ortega Guitars concert UWNY-4-CC strings
- FREE deluxe gig bag included



CUTAWAY/PICKUP

Concert scale: 376 mm (14.80")
width at nut: 35 mm (1.38")



RUWN-CE



- Walnut top, satin open pore
- Walnut back & side, satin open pore
- Reversed headstock, 4 in line
- Okoume neck, satin finish
- Maple top, bottom & fretboard binding
- Tecwood fretboard & bridge
- Ortega MagusUke preamp/pickup system
- Die cast tuning machines, gold w/black buttons
- Ortega Guitars concert UWNY-4-CC strings
- FREE deluxe gig bag included



LIZARD SERIES



PICKUP



Soprano scale: 346 mm (13.76")
width at nut: 35 mm (1.38")

LIZARD-SO-GB

- Paldao top, satin finish
- Paldao back & side, satin finish
- Mahogany neck, gloss finish
- Walnut binding
- Walnut fretboard & bridge
- Maple Lizard fretboard inlay
- Ortega MagusUke preamp/pickup system
- Die cast tuning machines, gold
- Ortega Guitars soprano UWNY-4-SO strings
- FREE deluxe gig bag included



PICKUP



Concert scale: 380 mm (14.96")
width at nut: 36 mm (1.42")

LIZARD-CC-GB

- Paldao top, satin finish
- Paldao back & side, satin finish
- Mahogany neck, gloss finish
- Walnut binding
- Walnut fretboard & bridge
- Maple Lizard fretboard inlay
- Ortega MagusUke preamp/pickup system
- Die cast tuning machines, gold
- Ortega Guitars concert UWNY-4-CC strings
- FREE deluxe gig bag included



PICKUP



Tenor scale: 432 mm (17.00")
width at nut: 37 mm (1.45")

LIZARD-TE-GB

- Paldao top, satin finish
- Paldao back & side, satin finish
- Mahogany neck, gloss finish
- Walnut binding
- Walnut fretboard & bridge
- Maple Lizard fretboard inlay
- Ortega MagusUke preamp/pickup system
- Die cast tuning machines, gold
- Ortega Guitars tenor UWNY-4-TE strings
- FREE deluxe gig bag included



PICKUP



Bass scale: 510 mm (20.08")
width at nut: 45 mm (1.77")

LIZZY-BS-GB

- Mahogany top, satin finish
- Mahogany back & side, satin finish
- Mahogany neck, satin finish
- Walnut fretboard & bridge
- Black ABS binding/white purfling
- Ortega MagusUkebass preamp/pickup system
- 15 frets
- 2way truss rod built-in
- Aquila Thundergut Ukebass 68U strings, short scale
- FREE deluxe gig bag & nylon strap incl.





PICKUP

LINED FRETLESS

Bass

scale: 510 mm (20.08")
width at nut: 45 mm (1.77")

LIZZY-BSFL-GB



- Mahogany top, satin finish
- Mahogany back & side, satin finish
- Mahogany neck, satin finish
- Walnut fretboard & bridge
- Black ABS binding/white purfling
- Ortega MagusUkebass preamp/pickup system
- 2way truss rod built-in
- Aquila Thundergut Ukebass 68U strings, short scale
- FREE deluxe gig bag & nylon strap incl.

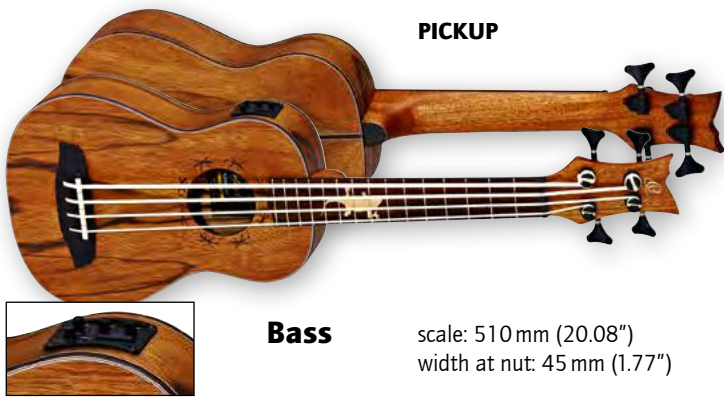

PICKUP

Bass

scale: 510 mm (20.08")
width at nut: 45 mm (1.77")

LIZARD-BS-GB



- Dao top, satin finish
- Dao back & side, satin finish
- Mahogany neck, satin finish
- Walnut fretboard & bridge
- Black ABS binding/white purfling
- Ortega MagusUkebass preamp/pickup system
- 15 frets
- 2way truss rod built-in
- Aquila Thundergut Ukebass 68U strings, short scale
- FREE deluxe gig bag & nylon strap incl.

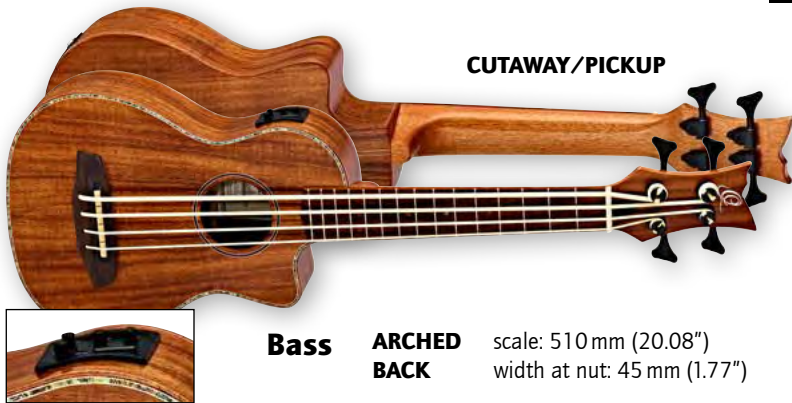

CUTAWAY/PICKUP

Bass

ARCHED BACK

scale: 510 mm (20.08")
width at nut: 45 mm (1.77")

CAIMAN-BS-GB



- Acacia top, gloss finish
- Acacia back (arched) & side, gloss finish
- Mahogany neck, gloss finish
- Walnut fretboard & bridge
- Mahogany body & fretboard binding
- Abalone style purfling
- Mahogany dot fretboard inlays
- Ortega Magus Ukebass preamp/pickup system
- 2way truss rod built-in
- Custom made indirect Ukebass tuning machines, black
- Aquila Thundergut Ukebass 68U strings, short scale
- FREE deluxe gig bag & nylon strap incl.

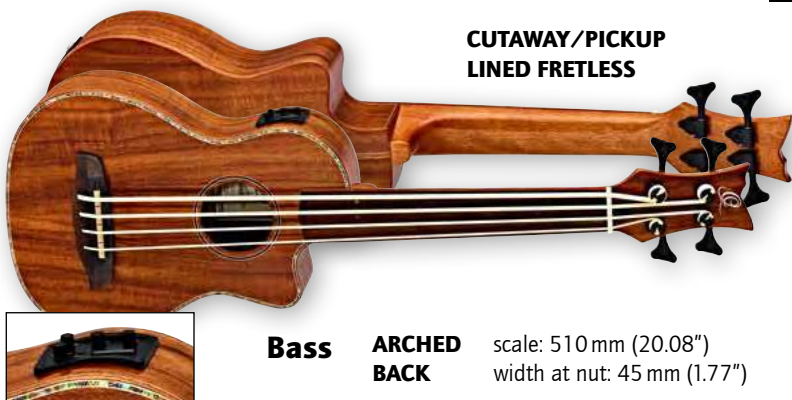

**CUTAWAY/PICKUP
LINED FRETLESS**

Bass

ARCHED BACK

scale: 510 mm (20.08")
width at nut: 45 mm (1.77")

CAIMAN-FL-GB



- Acacia top, gloss finish
- Acacia back (arched) & side, gloss finish
- Mahogany neck, gloss finish
- Walnut fretboard & bridge
- Mahogany body & fretboard binding
- Abalone style purfling
- Mahogany dot fretboard inlays/lines
- Ortega Magus Ukebass preamp/pickup system
- 2way truss rod built-in
- Custom made indirect Ukebass tuning machines, black
- Aquila Thundergut Ukebass 68U strings, short scale
- FREE deluxe gig bag & nylon strap incl.



ACACIA SERIES SOLID TOP & SOLID BOTTOM – OPEN PORE



Soprano scale: 344 mm (13.54")
width at nut: 35 mm (1.38")

RUACA-SO



- Solid acacia top, satin open pore
- Solid acacia back, satin open pore
- Acacia side, satin open pore
- Okoume neck, satin finish
- Padouk top, bottom & fretboard binding
- Tecwood fretboard & bridge
- Die cast tuning machines, gold w/black buttons
- Ortega Guitars soprano UWNY-4-SO strings
- FREE deluxe gig bag included



Concert scale: 376 mm (14.80")
width at nut: 35 mm (1.38")

RUACA-CC



- Solid acacia top, satin open pore
- Solid acacia back, satin open pore
- Acacia side, satin open pore
- Okoume neck, satin finish
- Padouk top, bottom & fretboard binding
- Tecwood fretboard & bridge
- Die cast tuning machines, gold w/black buttons
- Ortega Guitars concert UWNY-4-CC strings
- FREE deluxe gig bag included



Tenor scale: 430 mm (16.93")
width at nut: 35 mm (1.38")

RUACA-TE



- Solid acacia top, satin open pore
- Solid acacia back, satin open pore
- Acacia side, satin open pore
- Okoume neck, satin finish
- Padouk top, bottom & fretboard binding
- Tecwood fretboard & bridge
- Die cast tuning machines, gold w/black buttons
- Ortega Guitars tenor UWNY-4-TE strings
- FREE deluxe gig bag included



Baritone scale: 510 mm (20.08")
width at nut: 38 mm (1.49")

RUACA-BA



- Solid acacia top, satin open pore
- Solid acacia back, satin open pore
- Acacia side, satin open pore
- Okoume neck, satin finish
- Padouk top, bottom & fretboard binding
- Tecwood fretboard & bridge
- Die cast tuning machines, gold w/black buttons
- Ortega Guitars baritone UWNY-4-BA strings
- FREE deluxe gig bag included

ROOT SERIES ALL SOLID MAHOGANY

RU10



Soprano scale: 350 mm (13.78")
width at nut: 36 mm (1.42")



- Solid mahogany top, satin finish
- Solid mahogany back & side, satin finish
- Mahogany neck, satin finish
- Ivory ABS binding
- Walnut fretboard & bridge
- Indirect tuning machines, gold
- Ortega Guitars soprano UWNY-4-SO strings
- FREE deluxe gig bag included

RU11



Concert scale: 380 mm (14.96")
width at nut: 36 mm (1.42")



- Solid mahogany top, satin finish
- Solid mahogany back & side, satin finish
- Mahogany neck, satin finish
- Ivory ABS binding
- Walnut fretboard & bridge
- Indirect tuning machines, gold
- Ortega Guitars concert UWNY-4-CC strings
- FREE deluxe gig bag included





ECLIPSE SERIES ALL SOLID MAHOGANY



**DOUBLE SOUNDHOLE
BUILT-IN ARMREST
ERGONOMIC CUTAWAY**

Concert

scale: 380 mm (14.96")
width at nut: 38 mm (1.49")

4 STRING

ECLIPSE-CC4



- Solid Mahogany top, gloss finish
- Solid Mahogany back & side, gloss finish
- Solid Okoume neck, gloss finish
- Slotted headstock
- Walnut top, bottom & fretboard binding
- Walnut rear headstock veneer
- Walnut fretboard & bridge
- Eclipse fretboard inlays, custom made
- Eclipse soundhole (top) custom design
- Bone nut & saddle
- Single tuning machines, gold
- Ortega concert UWNY-4-CC strings
- FREE deluxe gig bag included



**DOUBLE SOUNDHOLE
BUILT-IN ARMREST
ERGONOMIC CUTAWAY**

Tenor

scale: 430 mm (16.93")
width at nut: 38 mm (1.49")

6 STRING

ECLIPSE-TE6



- Solid Mahogany top, gloss finish
- Solid Mahogany back & side, gloss finish
- Solid Okoume neck, gloss finish
- Slotted headstock
- Walnut top, bottom & fretboard binding
- Walnut rear headstock veneer
- Walnut fretboard & bridge
- Eclipse fretboard inlays, custom made
- Eclipse soundhole (top) custom design
- Bone nut & saddle
- Classical tuning machines
- Aquila tenor 6string
- FREE deluxe gig bag included



**DOUBLE SOUNDHOLE
BUILT-IN ARMREST
ERGONOMIC CUTAWAY**

Tenor

scale: 430 mm (16.93")
width at nut: 38 mm (1.49")

8 STRING

ECLIPSE-TE8



- Solid Mahogany top, gloss finish
- Solid Mahogany back & side, gloss finish
- Solid Okoume neck, gloss finish
- Slotted headstock
- Walnut top, bottom & fretboard binding
- Walnut rear headstock veneer
- Walnut fretboard & bridge
- Eclipse fretboard inlays, custom made
- Eclipse soundhole (top) custom design
- Bone nut & saddle
- 8string tuning machines
- Aquila tenor 8string
- FREE deluxe gig bag included



RAVEN SERIES



scale: 394 mm (15.51")
width at nut: 35 mm (1.38")

OUBJ100-SBK



- 4string Ukulele-Banjo
- Hard maple neck
- Maple plywood resonator
- Ovangkol fretboard
- Maple plywood rim
- 18 brackets
- Chrome hardware
- Remo ebony head, black
- Open geared machine head
- D'Addario J92 Pro-Arte Ukulele strings, Concert
- FREE deluxe Banjo bag included



BONFIRE TIGER

This guitar-ukulele hybrid is our cross between a nylon 6string with a tenor ukulele body. Making this a perfect travel guitar, fun & easy to play, for all ages.

SERIES - GUITARLELES

GUITARLELES YOUR OPTIONS

scales and sizes

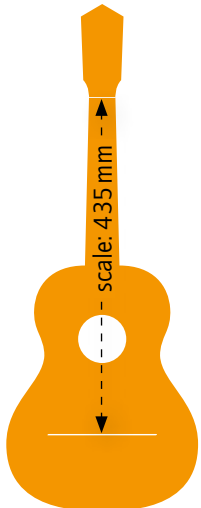

width at nut

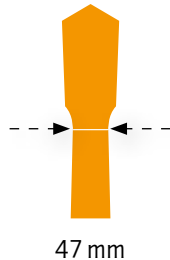

body



non cutaway



cutaway

features

bag



color/ finish variations



natural NT:
satin finish



flamed maho-
gany FMH:
gloss finish

wood variations: top

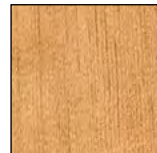

spruce

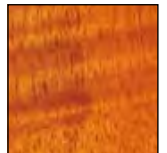

flamed
mahogany

strings

Aquila®

Aquila 96C Guitarlele strings

electronic



Preamp with built-in tuner

wood variations:
back & sides



mahogany



flamed
mahogany

RGL5



Guitarlele
scale: 435 mm
width at nut: 47 mm

- Spruce top, satin finish, laser engraved motif
- Mahogany back & side, satin finish
- Mahogany neck, satin finish
- 18 frets
- Walnut fretboard & bridge
- Aquila 96C Guitarlele strings

RGL5C



CUTAWAY

Guitarlele
scale: 435 mm
width at nut: 47 mm

- Spruce top, satin finish, laser engraved motif
- Mahogany back & side, satin finish
- Mahogany neck, satin finish
- 18 frets
- Walnut fretboard & bridge
- Aquila 96C Guitarlele strings

RGL5E

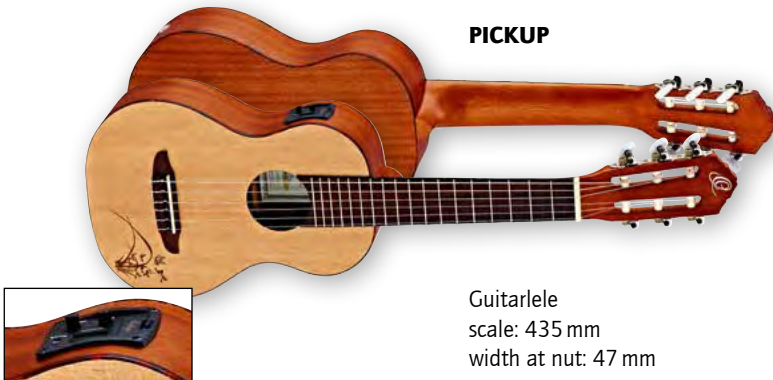

PICKUP

Guitarlele
scale: 435 mm
width at nut: 47 mm

- Spruce top, satin finish, laser engraved motif
- Mahogany back & side, satin finish
- Mahogany neck, satin finish
- 18 frets
- Ortega MagusUke preamp/pickup system with built-in tuner
- Walnut fretboard & bridge
- Aquila 96C Guitarlele strings

RGL5CE

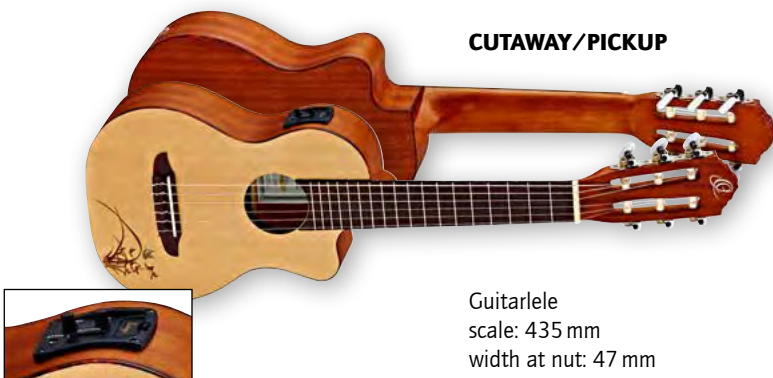

CUTAWAY/PICKUP

Guitarlele
scale: 435 mm
width at nut: 47 mm

- Spruce top, satin finish, laser engraved motif
- Mahogany back & side, satin finish
- Mahogany neck, satin finish
- 18 frets
- Ortega MagusUke preamp/pickup system with built-in tuner
- Walnut fretboard & bridge
- Aquila 96C Guitarlele strings



12072

Handwritten notes on a small piece of paper attached to the guitar body template, including the number '518' and some illegible text.

TIGER SERIES FLAMED MAHOGANY

RGL18FMH



scale: 435 mm
width at nut: 47 mm **FMH**
(flamed mahogany)



- Flamed mahogany top, gloss finish
- Flamed mahogany back & side, gloss finish
- Mahogany neck, satin finish
- 18 frets
- Walnut fretboard & bridge
- Aquila 96C Guitarlele strings
- FREE deluxe gig bag included

RGLE18FMH



PICKUP

scale: 435 mm
width at nut: 47 mm **FMH**
(flamed mahogany)



- Flamed mahogany top, gloss finish
- Flamed mahogany back & side, gloss finish
- Mahogany neck, satin finish
- 18 frets
- Ortega MagusUke preamp/pickup system with built-in tuner
- Walnut fretboard & bridge
- Aquila 96C Guitarlele strings
- FREE deluxe gig bag included





NYLON STRING GUITARS



Index	Page
Stomp Boxes	004
Ukuleles & Guitarleles	010
Nylon String Guitars	042
Student Series	044
Family Series	048
Family Series Pro	062
Feel Series	068
Traveler Series	076
Traditional Series	078
Custom Master Selection Series	082
Signature Series	086
Stage Series	090
★ The Private Room	092
Acoustic Basses	098
Banjos	112
Mandolins	120
Percussion	126
Accessories	134



STUDENT SERIES

Designed to be your first step in learning guitar.
With detailed care in offering a quality built instrument
for an entry budget, you'll find our STUDENT SERIES is
more than just for beginners.

STUDENT SERIES

YOUR OPTIONS

scales and sizes

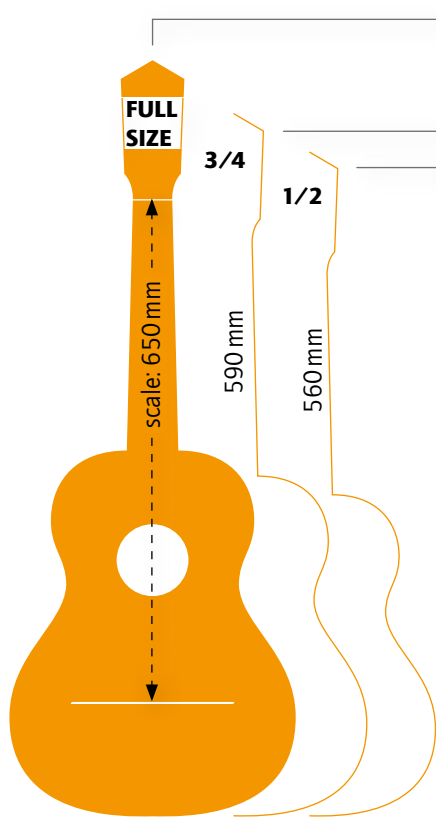

width at nut

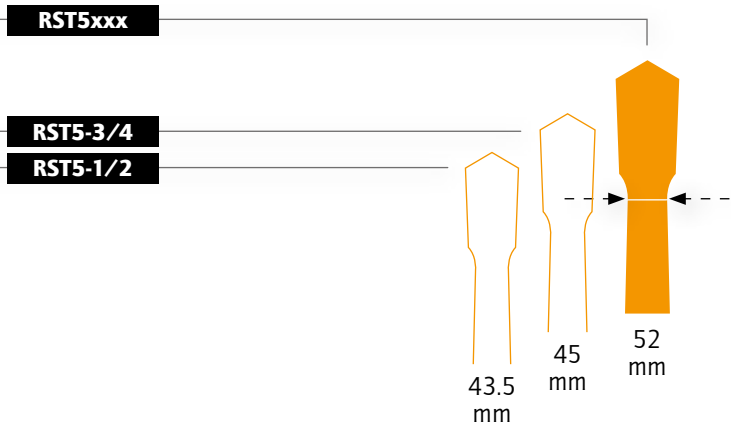

body



non cutaway

strings

ORTEGA®

features



6hole bridge



classical tuning machines

color/finish variations



natural gloss natural satin black satin wine red satin

wood variations: top



spruce

wood variations: back & sides



catalpa



STUDENT SERIES



SPRUCE TOP



1/2 size scale: 560 mm (gloss finish)
width at nut: 43.5 mm

RST5-1/2

- Spruce top, gloss finish
- Catalpa back & side, gloss finish
- ABS binding
- Mahogany neck, gloss finish
- Walnut fretboard & bridge
- Ortega 6hole bridge
- Classical tuning machines, chrome



3/4 size scale: 590 mm (gloss finish)
width at nut: 45 mm

RST5-3/4

- Spruce top, gloss finish
- Catalpa back & side, gloss finish
- ABS binding
- Mahogany neck, gloss finish
- Walnut fretboard & bridge
- Ortega 6hole bridge
- Classical tuning machines, chrome

**RST5**

- Spruce top, gloss finish
- Catalpa back & side, gloss finish
- ABS binding
- Mahogany neck, gloss finish
- Walnut fretboard & bridge
- Ortega 6hole bridge
- Classical tuning machines, chrome

full size scale: 650 mm (gloss
width at nut: 52 mm finish)

**RST5M**

- Spruce top, matt satin finish
- Catalpa back & side, matt satin finish
- ABS binding
- Mahogany neck, matt satin finish
- Walnut fretboard & bridge
- Ortega 6hole bridge
- Classical tuning machines, chrome

full size scale: 650 mm **M**
width at nut: 52 mm (matt satin
finish)

**RST5MBK**

- Spruce top, matt satin finish black
- Catalpa back & side, matt satin finish black
- ABS binding
- Mahogany neck, matt satin finish black
- Walnut fretboard & bridge
- Ortega 6hole bridge
- Classical tuning machines, chrome

full size scale: 650 mm **MBK**
width at nut: 52 mm (matt satin
finish black)

**RST5WR**

- Spruce top, matt satin finish wine red
- Catalpa back & side, matt satin finish wine red
- ABS binding
- Mahogany neck, matt satin finish wine red
- Walnut fretboard & bridge
- Ortega 6hole bridge
- Classical tuning machines, chrome

full size scale: 650 mm **MWR**
width at nut: 52 mm (matt satin
finish wine red)



FAMILY SERIES

Designed to fit the needs of everyone at every age and every skill level. With our largest selection you will find all body sizes from a quarter to full size with choices in color options and neck widths.

FAMILY SERIES

YOUR OPTIONS

scales and sizes

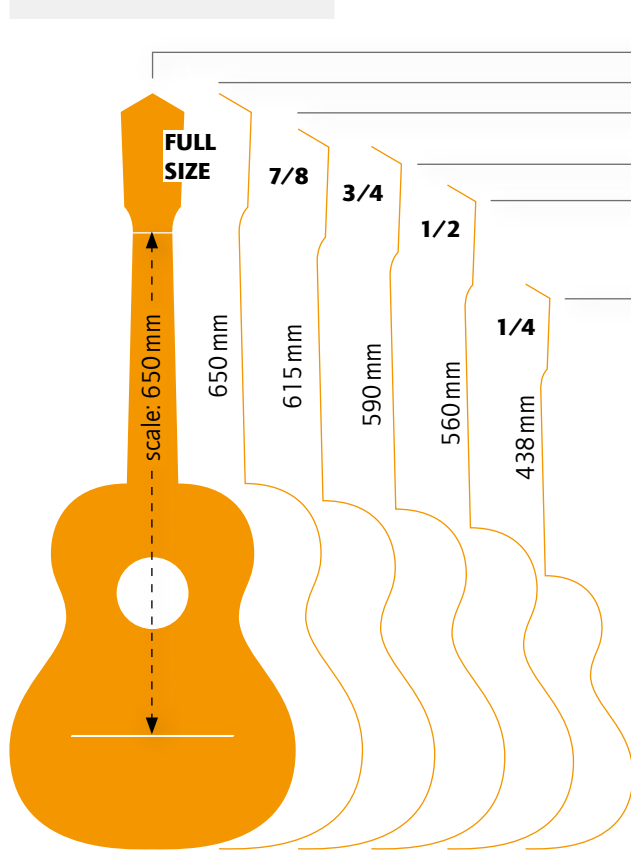

width at nut

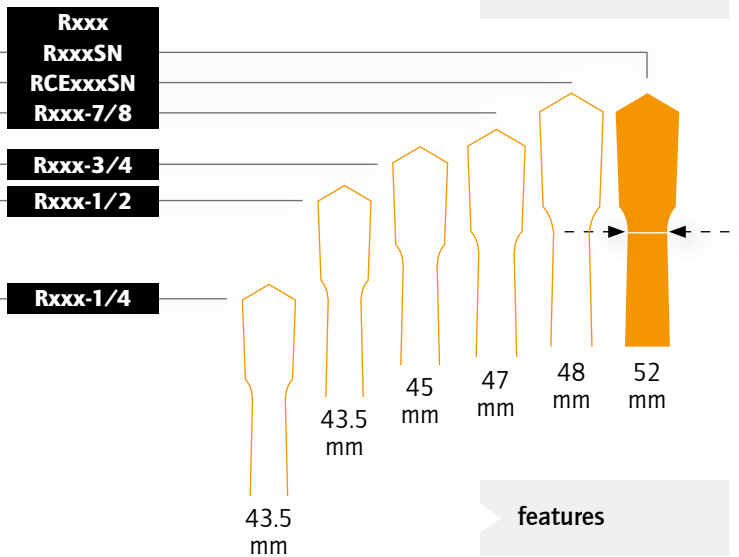

features

lefthand:
Rxxx **L**



body



non cutaway



cutaway



12hole bridge

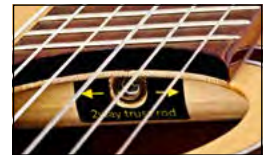

2way truss rod



bag/strap

strings

SAVAREZ

510CJ (4/4 & 7/8 size)
540CS (3/4 size)
540CXS (1/2 & 1/4 size)

electronic:
RCExxx



Preamp with built-in tuner

color/finish variations



natural NT:
satin finish

black BK:
gloss finish

wine red WR:
gloss finish

white WH:
gloss finish

wood variations: top



spruce

cedar

solid spruce

solid cedar

wood variations:
back & sides



mahogany



FAMILY SERIES



SPRUCE TOP



full size scale: 650 mm
width at nut: 52 mm

R121



- Spruce top, satin finish
- Mahogany back & side, satin finish
- Mahogany neck, satin finish
- Walnut fretboard & bridge
- Ortega 12hole bridge
- 2way truss rod built-in
- Savarez 510CJ strings
- FREE deluxe gig bag included



full size scale: 650 mm
width at nut: 48 mm **SN**
(slim neck)

R121SN



- Spruce top, satin finish
- Mahogany back & side, satin finish
- Mahogany neck, satin finish
- Walnut fretboard & bridge
- Ortega 12hole bridge
- 2way truss rod built-in
- Savarez 510CJ strings
- FREE deluxe gig bag included



LEFTHAND

full size scale: 650 mm
width at nut: 52 mm

R121L



- Spruce top, satin finish
- Mahogany back & side, satin finish
- Mahogany neck, satin finish
- Walnut fretboard & bridge
- Ortega 12hole bridge
- 2way truss rod built-in
- Savarez 510CJ strings
- FREE deluxe gig bag included
- LEFTHAND

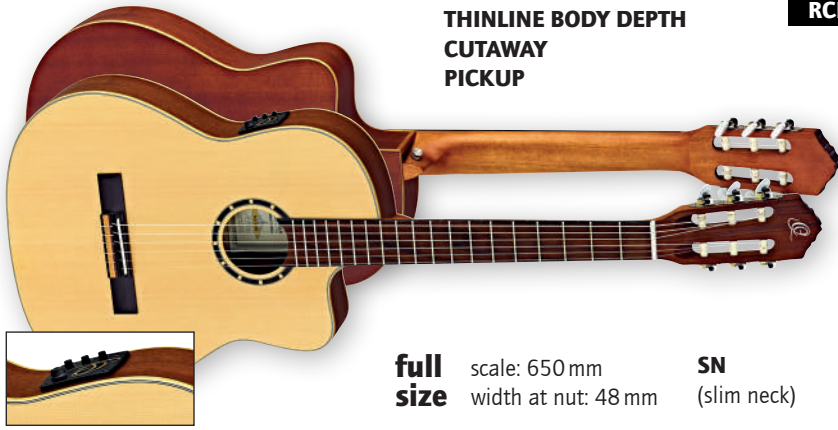

**THINLINE BODY DEPTH
CUTAWAY
PICKUP**

full size scale: 650 mm
width at nut: 48 mm **SN**
(slim neck)

RCE125SN



- Spruce top, satin finish
- Mahogany back & side, satin finish
- Thinline body, 85 mm, cutaway
- Mahogany neck, satin finish
- Walnut fretboard & bridge
- Ortega MagusPro preamp/pickup system with built-in tuner
- Ortega 12hole bridge
- 2way truss rod built-in
- Savarez 510CJ strings
- FREE deluxe gig bag included



7/8 size scale: 615 mm
width at nut: 47 mm

R121-7/8



- Spruce top, satin finish
- Mahogany back & side, satin finish
- Mahogany neck, satin finish
- Walnut fretboard & bridge
- Ortega 12hole bridge
- 2way truss rod built-in
- Savarez 510CJ strings
- FREE deluxe gig bag included



3/4 size scale: 590 mm
width at nut: 45 mm

R121-3/4



- Spruce top, satin finish
- Mahogany back & side, satin finish
- Mahogany neck, satin finish
- Walnut fretboard & bridge
- Ortega 12hole bridge
- 2way truss rod built-in
- Savarez 540CS strings
- FREE deluxe gig bag included



LEFTHAND

3/4 size scale: 590 mm
width at nut: 45 mm

R121L-3/4



- Spruce top, satin finish
- Mahogany back & side, satin finish
- Mahogany neck, satin finish
- Walnut fretboard & bridge
- Ortega 12hole bridge
- 2way truss rod built-in
- Savarez 540CS strings
- FREE deluxe gig bag included
- LEFTHAND



1/2 size scale: 560 mm
width at nut: 43.5 mm

R121-1/2



- Spruce top, satin finish
- Mahogany back & side, satin finish
- Mahogany neck, satin finish
- Walnut fretboard & bridge
- Ortega 12hole bridge
- 2way truss rod built-in
- Savarez 540CXS strings
- FREE deluxe gig bag included



1/4 size scale: 438 mm
width at nut: 43.5 mm

R121-1/4



- Spruce top, satin finish
- Mahogany back & side, satin finish
- Mahogany neck, satin finish
- Walnut fretboard & bridge
- Ortega 12hole bridge
- Savarez 540CXS strings
- FREE deluxe gig bag included



FAMILY SERIES



CEDAR TOP



full size scale: 650 mm
width at nut: 52 mm

R122



- Cedar top, satin finish
- Mahogany back & side, satin finish
- Mahogany neck, satin finish
- Walnut fretboard & bridge
- Ortega 12hole bridge
- 2way truss rod built-in
- Savarez 510CJ strings
- FREE deluxe gig bag included



full size scale: 650 mm
width at nut: 48 mm **SN**
(slim neck)

R122SN



- Cedar top, satin finish
- Mahogany back & side, satin finish
- Mahogany neck, satin finish
- Walnut fretboard & bridge
- Ortega 12hole bridge
- 2way truss rod built-in
- Savarez 510CJ strings
- FREE deluxe gig bag included



LEFTHAND

full size scale: 650 mm
width at nut: 52 mm

R122L



- Cedar top, satin finish
- Mahogany back & side, satin finish
- Mahogany neck, satin finish
- Walnut fretboard & bridge
- Ortega 12hole bridge
- 2way truss rod built-in
- Savarez 510CJ strings
- FREE deluxe gig bag included
- LEFTHAND



7/8 size scale: 615 mm
width at nut: 47 mm

R122-7/8



- Cedar top, satin finish
- Mahogany back & side, satin finish
- Mahogany neck, satin finish
- Walnut fretboard & bridge
- Ortega 12hole bridge
- 2way truss rod built-in
- Savarez 510CJ strings
- FREE deluxe gig bag included



3/4 size scale: 590 mm
width at nut: 45 mm

R122-3/4



- Cedar top, satin finish
- Mahogany back & side, satin finish
- Mahogany neck, satin finish
- Walnut fretboard & bridge
- Ortega 12hole bridge
- 2way truss rod built-in
- Savarez 540CS strings
- FREE deluxe gig bag included



LEFTHAND

3/4 size scale: 590 mm
width at nut: 45 mm

R122L-3/4



- Cedar top, satin finish
- Mahogany back & side, satin finish
- Mahogany neck, satin finish
- Walnut fretboard & bridge
- Ortega 12hole bridge
- 2way truss rod built-in
- Savarez 540CS strings
- FREE deluxe gig bag included
- LEFTHAND



1/2 size scale: 560 mm
width at nut: 43.5 mm

R122-1/2



- Cedar top, satin finish
- Mahogany back & side, satin finish
- Mahogany neck, satin finish
- Walnut fretboard & bridge
- Ortega 12hole bridge
- 2way truss rod built-in
- Savarez 540CXS strings
- FREE deluxe gig bag included



1/4 size scale: 438 mm
width at nut: 43.5 mm

R122-1/4

- Cedar top, satin finish
- Mahogany back & side, satin finish
- Mahogany neck, satin finish
- Walnut fretboard & bridge
- Ortega 12hole bridge
- Savarez 510CXS strings
- FREE deluxe gig bag included





FAMILY SERIES



SPRUCE TOP



full size scale: 650 mm width at nut: 52 mm **WR** (wine red)

R121WR



- Spruce top, gloss finish wine red
- Mahogany back & side, gloss finish wine red
- Mahogany neck, gloss finish wine red
- Walnut fretboard & bridge
- Ortega 12hole bridge
- 2way truss rod built-in
- Savarez 510CJ strings
- FREE deluxe gig bag included



full size scale: 650 mm width at nut: 48 mm **SN** (slim neck) **WR** (wine red)

R121SNWR



- Spruce top, gloss finish wine red
- Mahogany back & side, gloss finish wine red
- Mahogany neck, gloss finish wine red
- Walnut fretboard & bridge
- Ortega 12hole bridge
- 2way truss rod built-in
- Savarez 510CJ strings
- FREE deluxe gig bag included



LEFTHAND

full size scale: 650 mm width at nut: 52 mm **WR** (wine red)

R121LWR



- Spruce top, gloss finish wine red
- Mahogany back & side, gloss finish wine red
- Mahogany neck, gloss finish wine red
- Walnut fretboard & bridge
- Ortega 12hole bridge
- 2way truss rod built-in
- Savarez 510CJ strings
- FREE deluxe gig bag included
- LEFTHAND



7/8 size scale: 615 mm
width at nut: 47 mm **WR**
(wine red)

R121-7/8WR

- Spruce top, gloss finish wine red
- Mahogany back & side, gloss finish wine red
- Mahogany neck, gloss finish wine red
- Walnut fretboard & bridge
- Ortega 12hole bridge
- 2way truss rod built-in
- Savarez 510CJ strings
- FREE deluxe gig bag included



3/4 size scale: 590 mm
width at nut: 45 mm **WR**
(wine red)

R121-3/4WR

- Spruce top, gloss finish wine red
- Mahogany back & side, gloss finish wine red
- Mahogany neck, gloss finish wine red
- Walnut fretboard & bridge
- Ortega 12hole bridge
- 2way truss rod built-in
- Savarez 540CS strings
- FREE deluxe gig bag included



1/2 size scale: 560 mm
width at nut: 43.5 mm **WR**
(wine red)

R121-1/2WR

- Spruce top, gloss finish wine red
- Mahogany back & side, gloss finish wine red
- Mahogany neck, gloss finish wine red
- Walnut fretboard & bridge
- Ortega 12hole bridge
- 2way truss rod built-in
- Savarez 540CXS strings
- FREE deluxe gig bag included



1/4 size scale: 438 mm
width at nut: 43.5 mm **WR**
(wine red)

R121-1/4WR

- Spruce top, gloss finish wine red
- Mahogany back & side, gloss finish wine red
- Mahogany neck, gloss finish wine red
- Walnut fretboard & bridge
- Ortega 12hole bridge
- Savarez 540CXS strings
- FREE deluxe gig bag included



FAMILY SERIES

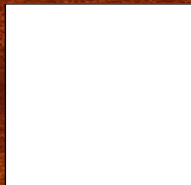

SPRUCE TOP



full size scale: 650 mm width at nut: 52 mm **WH** (white)

R121WH



- Spruce top, gloss finish white
- Mahogany back & side, gloss finish white
- Mahogany neck, gloss finish white
- Walnut fretboard & bridge
- Ortega 12hole bridge
- 2way truss rod built-in
- Savarez 510CJ strings
- FREE deluxe gig bag included



full size scale: 650 mm width at nut: 48 mm **SN** (slim neck) **WH** (white)

R121SNWH



- Spruce top, gloss finish white
- Mahogany back & side, gloss finish white
- Mahogany neck, gloss finish white
- Walnut fretboard & bridge
- Ortega 12hole bridge
- 2way truss rod built-in
- Savarez 510CJ strings
- FREE deluxe gig bag included



LEFTHAND

full size scale: 650 mm width at nut: 52 mm **WH** (white)

R121LWH



- Spruce top, gloss finish white
- Mahogany back & side, gloss finish white
- Mahogany neck, gloss finish white
- Walnut fretboard & bridge
- Ortega 12hole bridge
- 2way truss rod built-in
- Savarez 510CJ strings
- FREE deluxe gig bag included
- LEFTHAND



7/8 size scale: 615 mm
width at nut: 47 mm **WH**
(white)

R121-7/8WH

- Spruce top, gloss finish white
- Mahogany back & side, gloss finish white
- Mahogany neck, gloss finish white
- Walnut fretboard & bridge
- Ortega 12hole bridge
- 2way truss rod built-in
- Savarez 510CJ strings
- FREE deluxe gig bag included



3/4 size scale: 590 mm
width at nut: 45 mm **WH**
(white)

R121-3/4WH

- Spruce top, gloss finish white
- Mahogany back & side, gloss finish white
- Mahogany neck, gloss finish white
- Walnut fretboard & bridge
- Ortega 12hole bridge
- 2way truss rod built-in
- Savarez 540CS strings
- FREE deluxe gig bag included



1/2 size scale: 560 mm
width at nut: 43.5 mm **WH**
(white)

R121-1/2WH

- Spruce top, gloss finish white
- Mahogany back & side, gloss finish white
- Mahogany neck, gloss finish white
- Walnut fretboard & bridge
- Ortega 12hole bridge
- 2way truss rod built-in
- Savarez 540CXS strings
- FREE deluxe gig bag included



1/4 size scale: 438 mm
width at nut: 43.5 mm **WH**
(white)

R121-1/4WH

- Spruce top, gloss finish white
- Mahogany back & side, gloss finish white
- Mahogany neck, gloss finish white
- Walnut fretboard & bridge
- Ortega 12hole bridge
- Savarez 540CXS strings
- FREE deluxe gig bag included





FAMILY SERIES

SPRUCE TOP



R221BK

full size scale: 650 mm
width at nut: 52 mm **BK**
(black)



- Spruce top, gloss finish black
- Mahogany back & side, gloss finish black
- Mahogany neck, gloss finish black
- Walnut fretboard & bridge
- Mahogany body & fretboard binding
- White abalone style purfling
- Ortega 12hole bridge
- 2way truss rod built-in
- Savarez 510CJ strings
- FREE deluxe gig bag included



R221SNBK

full size scale: 650 mm
width at nut: 48 mm **SN** **BK**
(slim neck) (black)



- Spruce top, gloss finish black
- Mahogany back & side, gloss finish black
- Mahogany neck, gloss finish black
- Walnut fretboard & bridge
- Mahogany body & fretboard binding
- White abalone style purfling
- Ortega 12hole bridge
- 2way truss rod built-in
- Savarez 510CJ strings
- FREE deluxe gig bag included



R221BK-7/8

7/8 size scale: 615 mm
width at nut: 47 mm **BK**
(black)



- Spruce top, gloss finish black
- Mahogany back & side, gloss finish black
- Mahogany neck, gloss finish black
- Walnut fretboard & bridge
- Mahogany body & fretboard binding
- White abalone style purfling
- Ortega 12hole bridge
- 2way truss rod built-in
- Savarez 510CJ strings
- FREE deluxe gig bag included



3/4 size scale: 590 mm
width at nut: 45 mm **BK** (black)

R221BK-3/4

- Spruce top, gloss finish black
- Mahogany back & side, gloss finish black
- Mahogany neck, gloss finish black
- Walnut fretboard & bridge
- Mahogany body & fretboard binding
- White abalone style purfling
- Ortega 12hole bridge
- 2way truss rod built-in
- Savarez 540CS strings
- FREE deluxe gig bag included



thick padding



closable neck rest



SAFE and STYLISH

The Ortega Guitars deluxe gig bags are perfect for keeping your instrument safe when resting at home or on the road. Thick padded walls and a soft neck brace fasten your guitar securely for stabilization. Multiple accessory compartments help with organization and adjustable backpack shoulder straps add comfort when on the go.



FAMILY SERIES PRO



**SOLID
SPRUCE TOP**



full size scale: 650 mm
width at nut: 52 mm

R133



- Solid Canadian Engelmann spruce top, gloss finish
- Mahogany back & side, satin finish
- Mahogany neck, satin finish
- Walnut fretboard & bridge
- Ortega 12hole bridge
- 2way truss rod built-in
- Savarez 510CJ strings
- FREE deluxe gig bag included



full size scale: 650 mm **SN**
width at nut: 48 mm (slim neck)

R133SN



- Solid Canadian Engelmann spruce top, gloss finish
- Mahogany back & side, satin finish
- Mahogany neck, satin finish
- Walnut fretboard & bridge
- Ortega 12hole bridge
- 2way truss rod built-in
- Savarez 510CJ strings
- FREE deluxe gig bag included



3/4 size scale: 590 mm
width at nut: 45 mm

R133-3/4



- Solid Canadian Engelmann spruce top, gloss finish
- Mahogany back & side, satin finish
- Mahogany neck, satin finish
- Walnut fretboard & bridge
- Ortega 12hole bridge
- 2way truss rod built-in
- Savarez 540 CS strings
- FREE deluxe gig bag included

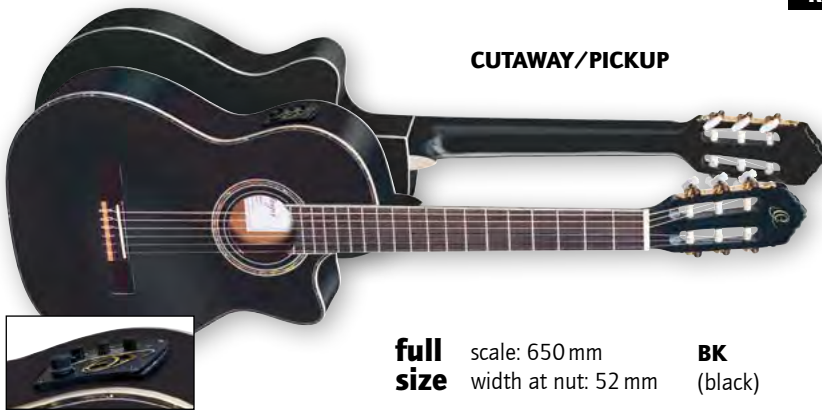

CUTAWAY/PICKUP

full size scale: 650 mm width at nut: 52 mm **BK** (black)

RCE141BK

- Solid Canadian Engelmann spruce top, gloss finish black
- Mahogany back & side, gloss finish black
- Mahogany neck, gloss finish black
- Walnut fretboard (flat) & bridge
- Ortega MagusPro preamp/pickup system with built-in tuner
- Ortega 12hole bridge
- 2way truss rod built-in
- Savarez 510CJ strings
- FREE deluxe gig bag & nylon strap incl.



THINLINE BODY DEPTH CUTAWAY/PICKUP

full size scale: 650 mm width at nut: 48 mm **SN** (slim neck) **BK** (black)

RCE145BK

- Solid Canadian Engelmann spruce top, gloss finish black
- Mahogany back & side, gloss finish black
- Mahogany neck, gloss finish black
- Walnut fretboard (flat) & bridge
- Ortega MagusPro preamp/pickup system with built-in tuner
- Ortega 12hole bridge
- 2way truss rod built-in
- Savarez 510CJ strings
- FREE deluxe gig bag & nylon strap incl.

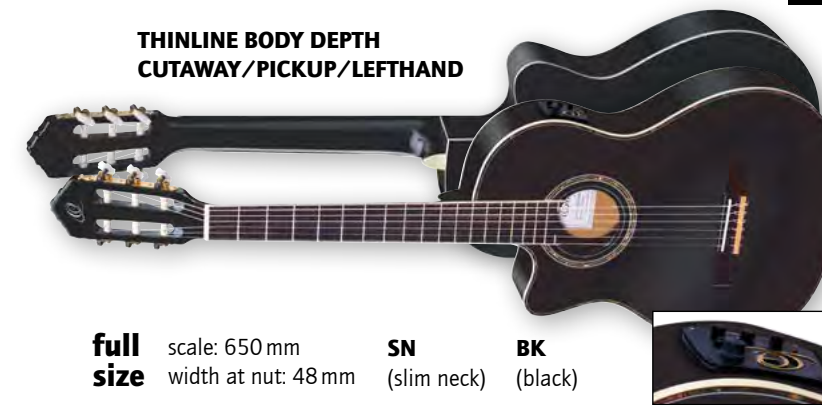

THINLINE BODY DEPTH CUTAWAY/PICKUP/LEFTHAND

full size scale: 650 mm width at nut: 48 mm **SN** (slim neck) **BK** (black)

RCE145LBK

- Solid Canadian Engelmann spruce top, gloss finish black
- Mahogany back & side, gloss finish black
- Mahogany neck, gloss finish black
- Walnut fretboard (flat) & bridge
- Ortega MagusPro preamp/pickup system with built-in tuner
- Ortega 12hole bridge
- 2way truss rod built-in
- Savarez 510CJ strings
- FREE deluxe gig bag & nylon strap incl.
- LEFTHAND



THINLINE BODY DEPTH CUTAWAY/PICKUP

full size scale: 650 mm width at nut: 48 mm **SN** (slim neck) **WH** (white)

RCE145WH

- Solid Canadian Engelmann spruce top, gloss finish white
- Mahogany back & side, gloss finish white
- Mahogany neck, gloss finish white
- Walnut fretboard (flat) & bridge
- Ortega MagusPro preamp/pickup system with built-in tuner
- Ortega 12hole bridge
- 2way truss rod built-in
- Savarez 510CJ strings
- FREE deluxe gig bag & nylon strap incl.





FAMILY SERIES PRO



**SOLID
CEDAR TOP**



full size scale: 650 mm
width at nut: 52 mm

R131

- Solid Canadian Western Red Cedar top, satin finish
- Mahogany back & side, satin finish
- Mahogany neck, satin finish
- Walnut fretboard & bridge
- Ortega 12hole bridge
- 2way truss rod built-in
- Savarez 510CJ strings
- FREE deluxe gig bag included



CUTAWAY/PICKUP

full size scale: 650 mm
width at nut: 52 mm

RCE131

- Solid Canadian Western Red Cedar top, satin finish
- Mahogany back & side, satin finish
- Mahogany neck, satin finish
- Walnut fretboard (flat) & bridge
- Ortega MagusPro preamp/pickup system with built-in tuner
- Ortega 12hole bridge
- 2way truss rod built-in
- Savarez 510CJ strings
- FREE deluxe gig bag & nylon strap incl.



LEFTHAND



full size scale: 650 mm
width at nut: 52 mm

R131L

- Solid Canadian Western Red Cedar top, satin finish
- Mahogany back & side, satin finish
- Mahogany neck, satin finish
- Walnut fretboard & bridge
- Ortega 12hole bridge
- 2way truss rod built-in
- Savarez 510CJ strings
- FREE deluxe gig bag included
- LEFTHAND



**CUTAWAY/PICKUP
LEFTHAND**



full size scale: 650 mm
width at nut: 52 mm

RCE131L

- Solid Canadian Western Red Cedar top, satin finish
- Mahogany back & side, satin finish
- Mahogany neck, satin finish
- Walnut fretboard (flat) & bridge
- Ortega MagusPro preamp/pickup system with built-in tuner
- Ortega 12hole bridge
- 2way truss rod built-in
- Savarez 510CJ strings
- FREE deluxe gig bag & nylon strap incl.
- LEFTHAND



R131SN



full size scale: 650 mm
width at nut: 48 mm **SN** (slim neck)

- Solid Canadian Western Red Cedar top, satin finish
- Mahogany back & side, satin finish
- Mahogany neck, satin finish
- Walnut fretboard & bridge
- Ortega 12hole bridge
- 2way truss rod built-in
- Savarez 510CJ strings
- FREE deluxe gig bag included



RCE131SN



CUTAWAY/PICKUP

full size scale: 650 mm
width at nut: 48 mm **SN** (slim neck)

- Solid Canadian Western Red Cedar top, satin finish
- Mahogany back & side, satin finish
- Mahogany neck, satin finish
- Walnut fretboard (flat) & bridge
- Ortega MagusPro preamp/pickup system with built-in tuner
- Ortega 12hole bridge
- 2way truss rod built-in
- Savarez 510CJ strings
- FREE deluxe gig bag & nylon strap incl.





full size scale: 650 mm
width at nut: 52 mm **WR**
(wine red)

R131WR



- Solid Canadian Western Red Cedar top, gloss finish wine red (transparent)
- Mahogany back & side, gloss finish wine red (transparent)
- Mahogany neck, gloss finish wine red (transparent)
- Walnut fretboard & bridge
- Ortega 12hole bridge
- 2way truss rod built-in
- Savarez 510CJ strings
- FREE deluxe gig bag included



full size scale: 650 mm
width at nut: 48 mm **SN** **WR**
(slim neck) (wine red)

R131SN-WR



- Solid Canadian Western Red Cedar top, gloss finish wine red (transparent)
- Mahogany back & side, gloss finish wine red (transparent)
- Mahogany neck, gloss finish wine red (transparent)
- Walnut fretboard & bridge
- Ortega 12hole bridge
- 2way truss rod built-in
- Savarez 510CJ strings
- FREE deluxe gig bag included





Innovative 12hole bridge allows for a greater break angle providing a cleaner, crisper sound and faster string replacement.



FEEL SERIES

Made with either Solid Canadian Spruce or Solid Red Cedar tops, paired with Mahogany or Walnut back and sides, for a better and more resonant tone. While still using the traditional Spanish heel we offer more comfortable slim and medium neck options for today's player.

FEEL SERIES

YOUR OPTIONS

scales and sizes

width at nut

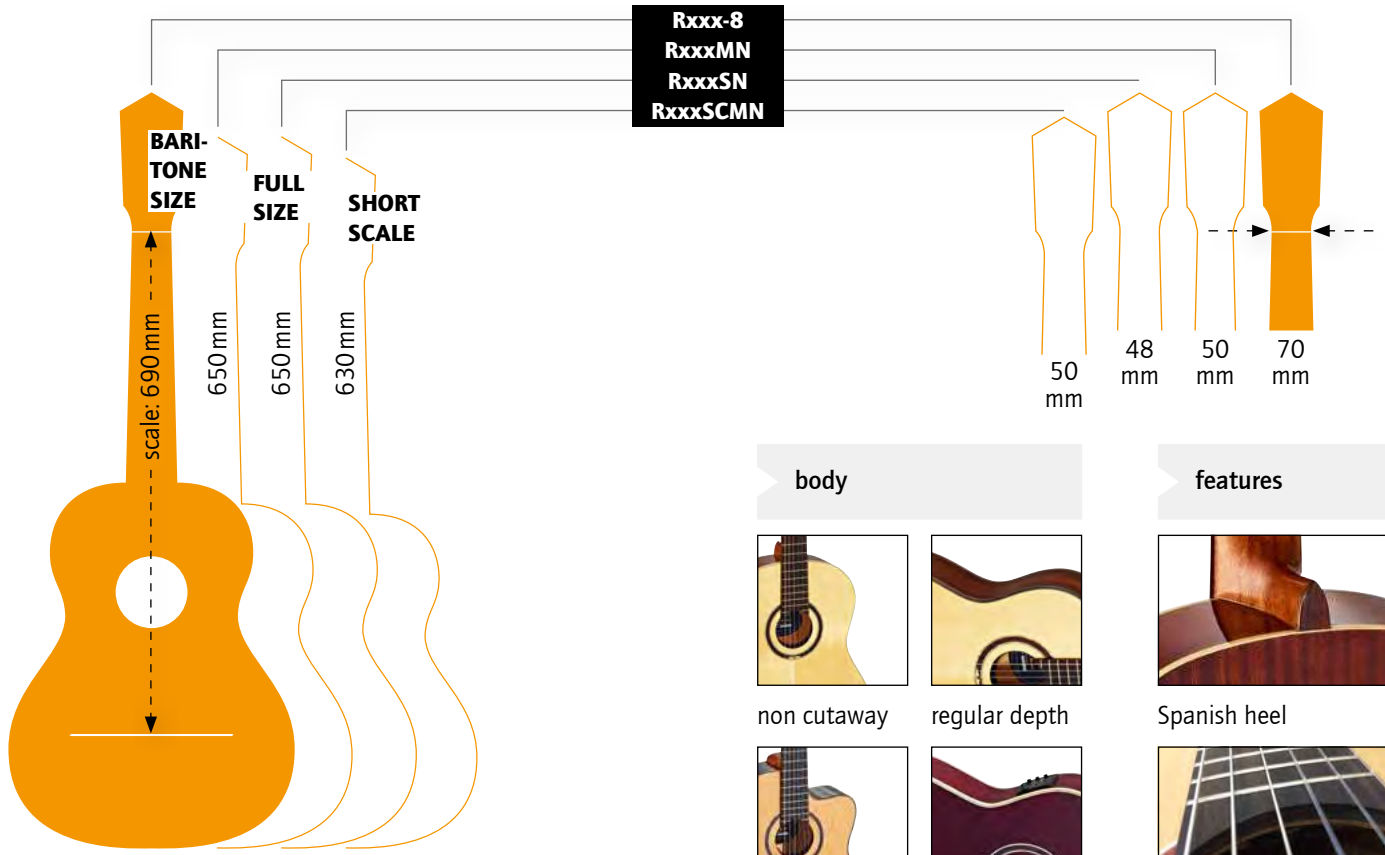

body



non cutaway



regular depth



cutaway



thinline

features



Spanish heel



curved fretboard



14th fret heel to body connection



12hole/16hole bridge



2way truss rod



bag/strap

color/finish variations



natural NT:
gloss finish



black BK:
gloss finish



tobacco
sunburst TSB:
gloss finish
(top only)

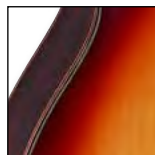

honey
burst HSB:
gloss finish
(top only)



stained red STR:
gloss finish

lefthand: RxxxL



strings



Savarez 500CJ strings
Ortega custom 8string

electronics: RCExxx



Preamp with
built-in tuner



wood variations: top



solid spruce



solid cedar



mahogany



walnut

wood variations:
back & sides



FEEL SERIES

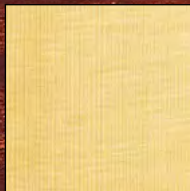

**SOLID
SPRUCE TOP**



SPANISH HEEL

scale: 650 mm
width at nut: 48 mm **SN**
(slim neck)

R138SN

- Solid Alaska Sitka spruce top, gloss finish
- Sapele back & side, gloss finish
- Mahogany neck, gloss finish
- Blackwood fretboard & bridge
- Ortega 12hole bridge
- Ortega signature walnut/maple/white pearl rosette
- 2way truss rod built-in
- Savarez 500CJ strings
- FREE deluxe gig bag included



**SPANISH HEEL
CUTAWAY/PICKUP**

scale: 650 mm
width at nut: 48 mm **SN**
(slim neck)

RCE138SN

- Solid Alaska Sitka spruce top, gloss finish
- Sapele back & side, gloss finish
- Mahogany neck, gloss finish
- Blackwood fretboard & bridge
- Ortega MagusPro preamp/pickup system with built-in tuner
- Ortega 12hole bridge
- Ortega signature walnut/maple/white pearl rosette
- 2way truss rod built-in
- Savarez 500CJ strings
- FREE deluxe gig bag & nylon strap incl.



**SPANISH HEEL
LEFTHAND**



scale: 650 mm **SN**
width at nut: 48 mm (slim neck)

R138SN-L

- Solid Alaska Sitka spruce top, gloss finish
- Sapele back & side, gloss finish
- Mahogany neck, gloss finish
- Blackwood fretboard & bridge
- Ortega 12hole bridge
- Ortega signature walnut/maple/white pearl rosette
- 2way truss rod built-in
- Savarez 500CJ strings
- FREE deluxe gig bag included
- LETHAND



**SPANISH HEEL
CUTAWAY/PICKUP
LEFTHAND**

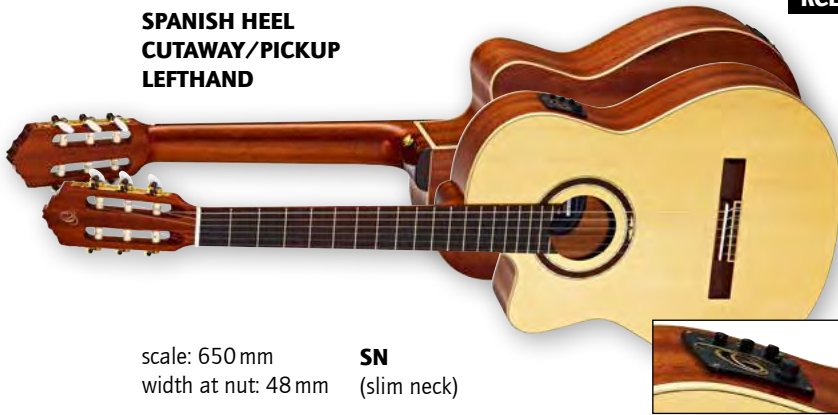

scale: 650 mm **SN**
width at nut: 48 mm (slim neck)

RCE138SN-L

- Solid Alaska Sitka spruce top, gloss finish
- Sapele back & side, gloss finish
- Mahogany neck, gloss finish
- Blackwood fretboard & bridge
- Ortega MagusPro preamp/pickup system with built-in tuner
- Ortega 12hole bridge
- Ortega signature walnut/maple/white pearl rosette
- 2way truss rod built-in
- Savarez 500CJ strings
- FREE deluxe gig bag & nylon strap incl.
- LETHAND



**THINLINE BODY DEPTH
SPANISH HEEL
CUTAWAY/PICKUP**



scale: 650 mm **SN** **STR**
width at nut: 48 mm (slim neck) (stained red)

RCE138-T4STR

- Solid Alaska Sitka spruce top, gloss finish stained red
- Sapele back & side, gloss finish stained red
- Mahogany neck, gloss finish stained
- 14th fret heel to body connection
- Curved (radius) blackwood fretboard & blackwood bridge
- Ortega MagusPro preamp/pickup system with built-in tuner
- Ortega 12hole bridge
- Ortega signature walnut/maple/white pearl rosette
- 2way truss rod built-in
- Savarez 500CJ strings
- FREE deluxe gig bag & nylon strap incl.



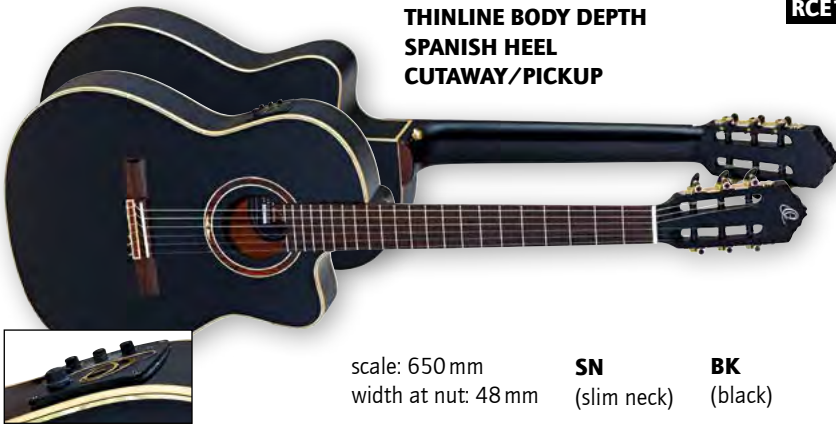

**THINLINE BODY DEPTH
SPANISH HEEL
CUTAWAY/PICKUP**

RCE138-T4BK

scale: 650 mm
width at nut: 48 mm **SN** **BK**
(slim neck) (black)

- Solid Alaska Sitka spruce top, gloss finish black
- Sapele back & side, gloss finish black
- Mahogany neck, gloss finish black
- 14th fret heel to body connection
- Curved (radius) blackwood fretboard & blackwood bridge
- Ortega MagusPro preamp/pickup system with built-in tuner
- Ortega 12hole bridge
- Ortega signature walnut/maple/white pearl rosette
- 2way truss rod built-in
- Savarez 500CJ strings
- FREE deluxe gig bag & nylon strap incl.



**THINLINE BODY DEPTH
SPANISH HEEL/LEFTHAND
CUTAWAY/PICKUP**

RCE138-T4BK-L

scale: 650 mm
width at nut: 48 mm **SN** **BK**
(slim neck) (black)

- Solid Alaska Sitka spruce top, gloss finish black
- Sapele back & side, gloss finish black
- Mahogany neck, gloss finish black
- 14th fret heel to body connection
- Curved (radius) blackwood fretboard & blackwood bridge
- Ortega MagusPro preamp/pickup system with built-in tuner
- Ortega 12hole bridge
- Ortega signature walnut/maple/white pearl rosette
- 2way truss rod built-in
- Savarez 500CJ strings
- FREE deluxe gig bag & nylon strap incl.
- LEFTHAND

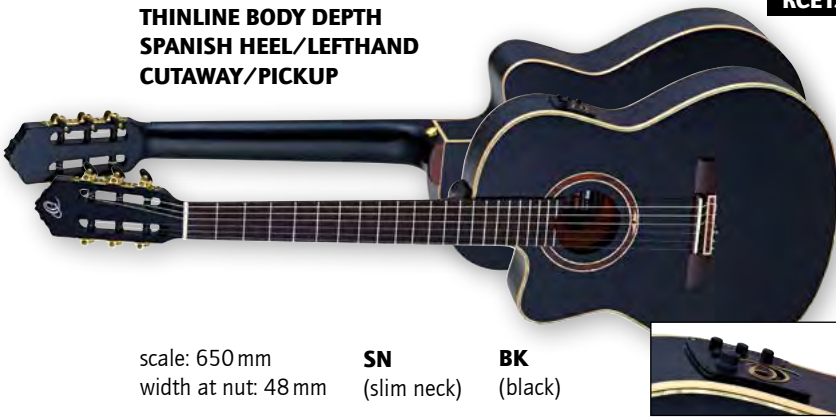

SPANISH HEEL

R158SN

scale: 650 mm
width at nut: 48 mm **SN**
(slim neck)

- Solid Alaska Sitka spruce top, gloss finish
- Walnut back & side, gloss finish
- Mahogany neck, gloss finish
- Blackwood fretboard & bridge
- Ortega 12hole bridge
- Ortega signature walnut/maple/white pearl rosette
- 2way truss rod built-in
- Savarez 500CJ strings
- FREE deluxe gig bag included



**SPANISH HEEL
CUTAWAY/PICKUP**

RCE158SN

scale: 650 mm
width at nut: 48 mm **SN**
(slim neck)

- Solid Alaska Sitka spruce top, gloss finish
- Walnut back & side, gloss finish
- Mahogany neck, gloss finish
- Blackwood fretboard & bridge
- Ortega MagusPro preamp/pickup system with built-in tuner
- Ortega 12hole bridge
- Ortega signature walnut/maple/white pearl rosette
- 2way truss rod built-in
- Savarez 500CJ strings
- FREE deluxe gig bag & nylon strap incl.



R158SN-TSB



SPANISH HEEL

scale: 650 mm **SN** **TSB**
width at nut: 48 mm (slim neck) (tobacco sunburst)



- Solid Alaska Sitka spruce top, tobacco sunburst (TSB) gloss finish
- Walnut back & side, gloss finish
- Mahogany neck, gloss finish
- Blackwood fretboard & bridge
- Ortega 12hole bridge
- Ortega signature walnut/maple/white pearl rosette
- 2way truss rod built-in
- Savarez 500CJ strings
- FREE deluxe gig bag included

RCE158SN-TSB



SPANISH HEEL CUTAWAY/PICKUP

scale: 650 mm **SN** **TSB**
width at nut: 48 mm (slim neck) (tobacco sunburst, top only)



- Solid Alaska Sitka spruce top, tobacco sunburst (TSB) gloss finish
- Walnut back & side, gloss finish
- Mahogany neck, gloss finish
- Blackwood fretboard & bridge
- Ortega MagusPro preamp/pickup system with built-in tuner
- Ortega 12hole bridge
- Ortega signature walnut/maple/white pearl rosette
- 2way truss rod built-in
- Savarez 500CJ strings
- FREE deluxe gig bag & nylon strap incl.

R158SN-HSB



SPANISH HEEL

scale: 650 mm **SN** **HSB**
width at nut: 48 mm (slim neck) (honey burst)



- Solid Alaska Sitka spruce top, honey burst (HSB) gloss finish
- Walnut back & side, gloss finish
- Mahogany neck, gloss finish
- Blackwood fretboard & bridge
- Ortega 12hole bridge
- Ortega signature walnut/maple/white pearl rosette
- 2way truss rod built-in
- Savarez 500CJ strings
- FREE deluxe gig bag included

RCE158SN-HSB



SPANISH HEEL CUTAWAY/PICKUP

scale: 650 mm **SN** **HSB**
width at nut: 48 mm (slim neck) (honey burst, top only)



- Solid Alaska Sitka spruce top, honey burst (HSB) gloss finish
- Walnut back & side, gloss finish
- Mahogany neck, gloss finish
- Blackwood fretboard & bridge
- Ortega MagusPro preamp/pickup system with built-in tuner
- Ortega 12hole bridge
- Ortega signature walnut/maple/white pearl rosette
- 2way truss rod built-in
- Savarez 500CJ strings
- FREE deluxe gig bag & nylon strap incl.



FEEL SERIES



**SOLID
CEDAR TOP**



SPANISH HEEL

scale: 650 mm
width at nut: 50 mm **MN**
(medium neck)

R139MN



- Solid North American cedar top, gloss finish
- Sapele back & side, gloss finish
- Mahogany neck, gloss finish
- Blackwood fretboard & bridge
- Ortega 12hole bridge
- Ortega signature walnut/maple/white pearl rosette
- 2way truss rod built-in
- Savarez 500CJ strings
- FREE deluxe gig bag included



**SPANISH HEEL
LEFTHAND**

scale: 650 mm
width at nut: 50 mm **MN**
(medium neck)

R139MN-L



- Solid North American cedar top, gloss finish
- Sapele back & side, gloss finish
- Mahogany neck, gloss finish
- Blackwood fretboard & bridge
- Ortega 12hole bridge
- Ortega signature walnut/maple/white pearl rosette
- 2way truss rod built-in
- Savarez 500CJ strings
- FREE deluxe gig bag included
- LETHAND



SPANISH HEEL

scale: 650 mm
width at nut: 50 mm **MN**
(medium neck)

R159MN



- Solid North American cedar top, gloss finish
- Walnut back & side, gloss finish
- Mahogany neck, gloss finish
- Blackwood fretboard & bridge
- Ortega 12hole bridge
- Ortega signature walnut/maple/white pearl rosette
- 2way truss rod built-in
- Savarez 500CJ strings
- FREE deluxe gig bag included



**SPANISH HEEL
CUTAWAY/PICKUP**

scale: 650 mm
width at nut: 50 mm **MN**
(medium neck)

RCE159MN

- Solid North American cedar top, gloss finish
- Walnut back & side, gloss finish
- Mahogany neck, gloss finish
- Blackwood fretboard & bridge
- Ortega MagusPro preamp/pickup system with built-in tuner
- Ortega 12hole bridge
- Ortega signature walnut/maple/white pearl rosette
- 2way truss rod built-in
- Savarez 500CJ strings
- FREE deluxe gig bag & nylon strap incl.



**SPANISH HEEL
CUTAWAY/PICKUP
LEFTHAND**

scale: 650 mm
width at nut: 50 mm **MN**
(medium neck)

RCE159MN-L

- Solid North American cedar top, gloss finish
- Walnut back & side, gloss finish
- Mahogany neck, gloss finish
- Blackwood fretboard & bridge
- Ortega MagusPro preamp/pickup system with built-in tuner
- Ortega 12hole bridge
- Ortega signature walnut/maple/white pearl rosette
- 2way truss rod built-in
- Savarez 500CJ strings
- FREE deluxe gig bag & nylon strap incl.
- LEFTHAND



**SPANISH HEEL
CUTAWAY/PICKUP**

scale: 650 mm
width at nut: 48 mm **SN**
(slim neck)

RCE159SN

- Solid North American cedar top, gloss finish
- Walnut back & side, gloss finish
- Mahogany neck, gloss finish
- Blackwood fretboard & bridge
- Ortega MagusPro preamp/pickup system with built-in tuner
- Ortega 12hole bridge
- Ortega signature walnut/maple/white pearl rosette
- 2way truss rod built-in
- Savarez 500CJ strings
- FREE deluxe gig bag & nylon strap incl.

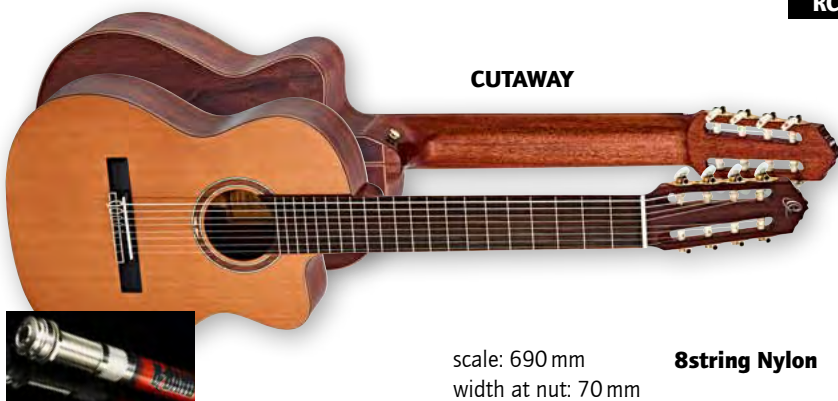

CUTAWAY

scale: 690 mm
width at nut: 70 mm **8string Nylon**

RCE159-8

- 8string NYLON STRING GUITAR
- Solid North American cedar top, gloss finish
- Walnut back & side, gloss finish
- Mahogany neck, gloss finish
- Tecwood fretboard (flat, 70 mm at nut / 78 mm on 14th fret / 90 mm on saddle)
- Tecwood bridge
- B.Band A1.2 preamp/pickup system
- Ortega 16hole bridge
- Ortega signature walnut/maple/white pearl rosette
- 2way truss rod built-in
- Ortega OCTA-8NS custom made strings
- FREE deluxe gig bag & nylon strap incl.





TRAVELER SERIES

Our short scale 6string nylon guitar is not only great for travel, equipped with electronics and a cutaway allows it to segue to the stage for live performance.



TRAVELER SERIES YOUR OPTIONS

scales and sizes

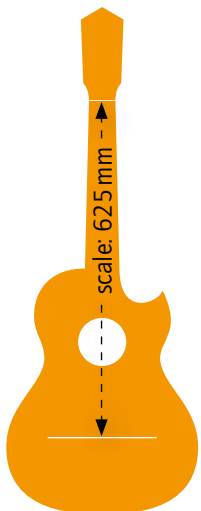

width at nut

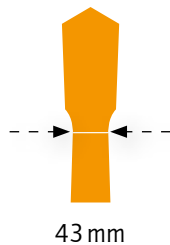

features



2way truss rod



bag/strap

wood variations:
top, back & sides



agathis red



agathis black



agathis white



mahogany

color/finish variations

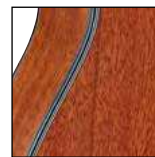

mahogany MM:
gloss finish



black BK:
gloss finish



red RD:
gloss finish



white WH:
gloss finish

electronic

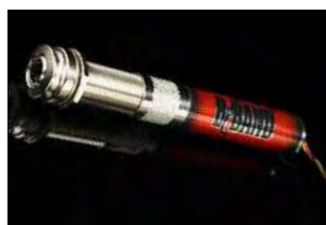

strings

SAVAREZ

Savarez 510CJ

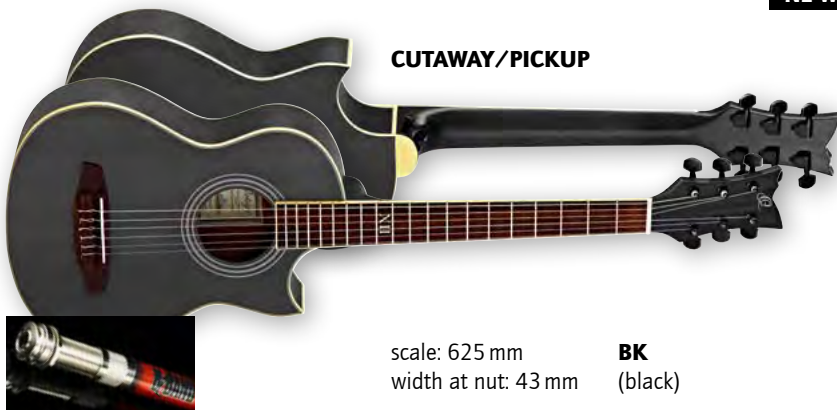
NL-WALKER-BK**CUTAWAY/PICKUP**

scale: 625 mm
width at nut: 43 mm **BK**
(black)



- Agathis top, black gloss finish
- Agathis back & side, black gloss finish
- Ivory ABS binding
- Mahogany neck, black gloss finish
- Acacia fretboard & bridge
- B.Band A1.2 preamp/pickup system
- Ortega die cast tuning machines, black
- 19 frets
- Savarez 510CJ strings
- FREE deluxe gig bag & nylon strap incl.

NL-WALKER-RD**CUTAWAY/PICKUP**

scale: 625 mm
width at nut: 43 mm **RD**
(red)

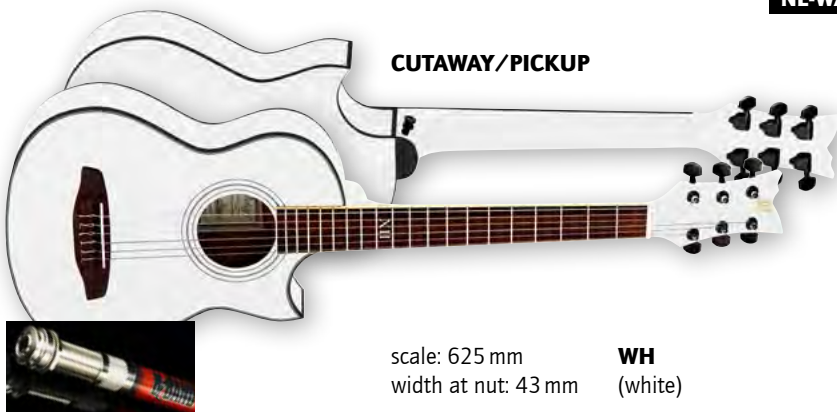

- Agathis top, red gloss finish
- Agathis back & side, red gloss finish
- Ivory ABS binding
- Mahogany neck, red gloss finish
- Sonokelin fretboard & bridge
- B.Band A1.2 preamp/pickup system
- Ortega die cast tuning machines, black
- 19 frets
- Savarez 510CJ strings
- FREE deluxe gig bag & nylon strap incl.

NL-WALKER-WH**CUTAWAY/PICKUP**

scale: 625 mm
width at nut: 43 mm **WH**
(white)



- Agathis top, white gloss finish
- Agathis back & side, white gloss finish
- Black ABS binding
- Mahogany neck, white gloss finish
- Sonokelin fretboard & bridge
- B.Band A1.2 preamp/pickup system
- Ortega die cast tuning machines, black
- 19 frets
- Savarez 510CJ strings
- FREE deluxe gig bag & nylon strap incl.

NL-WALKER-MM**CUTAWAY/PICKUP**

scale: 625 mm
width at nut: 43 mm **MM**
(mahogany)



- Mahogany top, gloss finish
- Mahogany back & side, gloss finish
- Black ABS binding
- Mahogany neck, gloss finish
- Acacia fretboard & bridge
- B.Band A1.2 preamp/pickup system
- Ortega die cast tuning machines, black
- 19 frets
- Savarez 510CJ strings
- FREE deluxe gig bag & nylon strap incl.



TRADITIONAL SERIES



In the tradition of classical and flamenco guitar making. These guitars are handcrafted in Spain with Solid Spruce or Cedar tops paired with select woods for back and sides, along with the Spanish heel neck joint, for a truly authentic sound and experience.

TRADITIONAL SERIES YOUR OPTIONS

scales and sizes

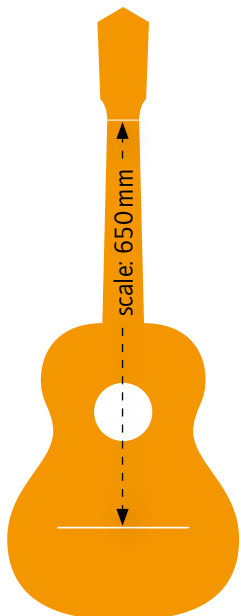

width at nut

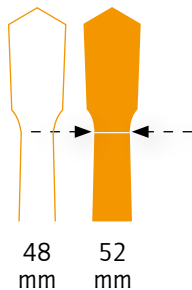

wood variations: back & sides

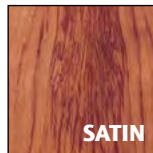

bubinga

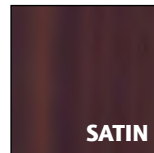

caoba



palo-rojo



mahogany

wood variations: top



solid Canadian spruce

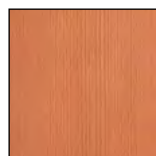

solid Red Western cedar



mongoy



maple

features



Spanish heel



12hole bridge



bag

lefthand: RxxxL



strings

SAVAREZ

Savarez 500CRJ

CEDAR TOP

R180



SPANISH HEEL

scale: 650 mm
width at nut: 52 mm



- Solid North American cedar top, satin finish
- Bubinga back & side, satin finish
- Maple binding
- Mahogany neck, satin finish
- Rosewood fretboard (flat) & bridge
- Ortega 12hole bridge
- Savarez 500CRJ strings
- Made in Spain
- FREE deluxe gig bag included

R180L



**SPANISH HEEL
LEFTHAND**

scale: 650 mm
width at nut: 52 mm



- Solid North American cedar top, satin finish
- Bubinga back & side, satin finish
- Maple binding
- Mahogany neck, satin finish
- Rosewood fretboard (flat) & bridge
- Ortega 12hole bridge
- Savarez 500CRJ strings
- Made in Spain
- FREE deluxe gig bag included
- LETHAND

R190



SPANISH HEEL

scale: 650 mm
width at nut: 52 mm



- Solid North American cedar top, satin finish
- Caoba back & side, satin finish
- Maple binding
- Mahogany neck, satin finish
- Rosewood fretboard (flat) & bridge
- Ortega 12hole bridge
- Savarez 500CRJ strings
- Made in Spain
- FREE deluxe gig bag included

R190G



SPANISH HEEL

scale: 650 mm
width at nut: 52 mm



- Solid North American cedar top, gloss finish
- Caoba back & side, gloss finish
- Maple binding
- Mahogany neck, gloss finish
- Rosewood fretboard (flat) & bridge
- Ortega 12hole bridge
- Savarez 500CRJ strings
- Made in Spain
- FREE deluxe gig bag included



CEDAR TOP

MADE IN SPAIN

R200



SPANISH HEEL

scale: 650 mm
width at nut: 52 mm



- Solid North American cedar top, gloss finish
- Palo-rojo back & side, gloss finish
- Maple binding
- Mahogany neck, gloss finish
- Rosewood fretboard (flat) & bridge
- Ortega 12hole bridge
- Savarez 500CRJ strings
- Made in Spain
- FREE deluxe gig bag included

R200SN



SPANISH HEEL

scale: 650 mm
width at nut: 48 mm **SN**
(slim neck)



- Solid North American cedar top, gloss finish
- Palo-rojo back & side, gloss finish
- Maple binding
- Mahogany neck, gloss finish
- Rosewood fretboard (flat) & bridge
- Ortega 12hole bridge
- Savarez 500CRJ strings
- Made in Spain
- FREE deluxe gig bag included

R200L



SPANISH HEEL
LEFTHAND

scale: 650 mm
width at nut: 52 mm



- Solid North American cedar top, gloss finish
- Palo-rojo back & side, gloss finish
- Maple binding
- Mahogany neck, gloss finish
- Rosewood fretboard (flat) & bridge
- Ortega 12hole bridge
- Savarez 500CRJ strings
- Made in Spain
- FREE deluxe gig bag included
- LEFTHAND

R220



SPANISH HEEL

scale: 650 mm
width at nut: 52 mm



- Solid North American cedar top, gloss finish
- Mongoy back & side, gloss finish
- Maple binding
- Mahogany neck, gloss finish
- Rosewood fretboard (flat) & bridge
- Ortega 12hole bridge
- Savarez 500CRJ strings
- Made in Spain
- FREE deluxe gig bag included

SPRUCE TOP

MADE IN
SPAIN

ortegaguitars.com

81

R210



SPANISH HEEL

scale: 650 mm
width at nut: 52 mm



- Solid North American spruce top, gloss finish
- Mahogany back & side, gloss finish
- Maple binding
- Mahogany neck, gloss finish
- Rosewood fretboard (flat) & bridge
- Ortega 12hole bridge
- Savarez 500CRJ strings
- Made in Spain
- FREE deluxe gig bag included

R270F



**FLAMENCO
SPANISH HEEL**

scale: 650 mm
width at nut: 52 mm



- Solid North American spruce top, gloss finish
- Maple back & side, gloss finish
- Rosewood binding
- Mahogany neck, gloss finish
- Rosewood fretboard (flat) & bridge (flat, Flamenco)
- Flamenco scratch plates
- Ortega 12hole bridge
- Savarez 500CRJ strings
- Made in Spain
- FREE deluxe gig bag included





CUSTOM MASTER SELECTION SERIES

MADE IN
SPAIN

We brought together our luthiers to create our collection of All Solid Classical guitars. Using hand selected exotic tonewoods and blending traditional guitar making methods with modern techniques, we bring you our finest collection.

CUSTOM MASTER SELECTION SERIES

YOUR OPTIONS

scales and sizes

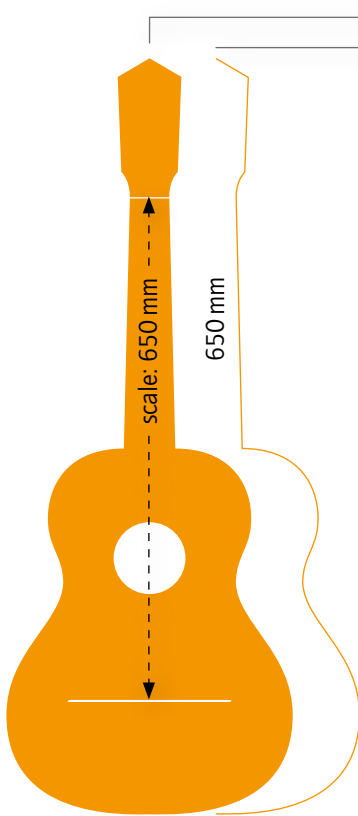

width at nut

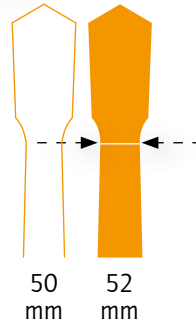

features



Spanish heel



12hole bridge



2way truss rod



bag/hard case

strings



Savarez 500CJ strings

wood variations: back & sides

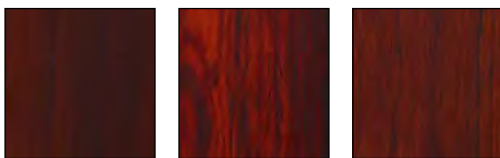

Indian rosewood

American cocobolo

Madagascar rosewood (certified)



European walnut

American Claro walnut

wood variations: top (all gloss finish)



European spruce

Canadian Red Western cedar



EUROPEAN SPRUCE TOP

MADE IN
SPAIN

M5CS



**ALL SOLID
SPANISH HEEL**

scale: 650 mm
width at nut: 52 mm



- Solid European spruce top, gloss finish
- Solid mahogany back & side, gloss finish
- Rosewood binding
- Mahogany neck, gloss finish
- Rosewood fretboard (flat) & bridge
- Savarez 500CJ strings
- Made in Spain
- FREE hardcase included

M6CS



**ALL SOLID
SPANISH HEEL**

scale: 650 mm
width at nut: 52 mm



- Solid European spruce top, gloss finish
- Solid German sycamore back & side, gloss finish
- Rosewood binding
- Mahogany neck, gloss finish
- Rosewood fretboard (flat) & bridge
- Savarez 500CJ strings
- Made in Spain
- FREE hardcase included

M8CS



**ALL SOLID
SPANISH HEEL**

scale: 650 mm
width at nut: 52 mm



- Solid European spruce top, gloss finish
- Solid Madagascar rosewood (certified) back & side, gloss finish
- Rosewood binding
- Mahogany neck, gloss finish
- Rosewood fretboard (flat) & bridge
- Savarez 500CJ strings
- Made in Spain
- FREE hardcase included

M9CS



**ALL SOLID
SPANISH HEEL**

scale: 650 mm
width at nut: 52 mm



- Solid European spruce top, gloss finish
- Solid American cocobolo back & side, gloss finish
- Rosewood binding
- Mahogany neck, gloss finish
- Rosewood fretboard (flat) & bridge
- Savarez 500CJ strings
- Made in Spain
- FREE hardcase included

CANADIAN RED WESTERN CEDAR TOP

MADE IN
SPAIN

ortegaguitars.com

85



**ALL SOLID
SPANISH HEEL**

scale: 650 mm
width at nut: 52 mm

M3CS



- Solid Canadian Red Western cedar top, gloss finish
- Solid Indian rosewood back & side, gloss finish
- Rosewood binding
- Mahogany neck, gloss finish
- Rosewood fretboard (flat) & bridge
- Savarez 500CJ strings
- Made in Spain
- FREE hardcase included



**ALL SOLID
SPANISH HEEL**

scale: 650 mm
width at nut: 52 mm

M4CS



- Solid Canadian Red Western cedar top, gloss finish
- Solid European walnut back & side, gloss finish
- Rosewood binding
- Mahogany neck, gloss finish
- Rosewood fretboard (flat) & bridge
- Savarez 500CJ strings
- Made in Spain
- FREE hardcase included



**ALL SOLID
SPANISH HEEL**

scale: 650 mm
width at nut: 52 mm

M7CS



- Solid Canadian Red Western cedar top, gloss finish
- Solid American Claro walnut back & side, gloss finish
- Rosewood binding
- Mahogany neck, gloss finish
- Rosewood fretboard (flat) & bridge
- Savarez 500CJ strings
- Made in Spain
- FREE hardcase included





SIGNATURE SERIES

MADE IN
SPAIN



photo: JR



Javier Reyes – Animals as Leaders
Signature models/custom made

**ALL SOLID
8STRING NYLON
SPANISH HEEL
CUTAWAY/PICKUP**



scale: 690 mm
width at nut: 70 mm



JRSM-COS

- Solid North American spruce top, gloss finish
- Solid American cocobolo back & side, gloss finish
- Mahogany neck, gloss finish
- Rosewood fretboard (flat, 70 mm at nut/ 78 mm on 14th fret/90 mm on saddle)
- Rosewood bridge
- L.R.BAGGS Element preamp/pickup system
- Ortega signature rosewood/maple/ white pearl rosette
- 2way truss rod built-in
- Ortega OCTA-8NS custom made strings - made in Germany
- Made in Spain
- FREE road case included

**ALL SOLID
8STRING NYLON
SPANISH HEEL
CUTAWAY/PICKUP**



scale: 690 mm
width at nut: 70 mm



JRSM-RWC

- Solid North American cedar top, gloss finish
- Solid Madagascar rosewood (certified) back & side, gloss finish
- Mahogany neck, gloss finish
- Rosewood fretboard (flat, 70 mm at nut/ 78 mm on 14th fret/90 mm on saddle)
- Rosewood bridge
- L.R.BAGGS Element preamp/pickup system
- Ortega signature rosewood/maple/ white pearl rosette
- 2way truss rod built-in
- Ortega OCTA-8NS custom made strings - made in Germany
- Made in Spain
- FREE road case included



MADE IN SPAIN

Ben Woods 

Ben Woods
Signature model/custom made

**THINLINE FLAMENCO STYLE
SPANISH HEEL
CUTAWAY/PICKUP**

BWSM



scale: 650 mm
width at nut: 52 mm

- Solid Western Red Cedar, gloss finish
- Indian rosewood back & side, gloss finish
- Thinline body depth (80 mm)
- Mahogany neck, gloss finish
- Rosewood binding
- Ebony fretboard (flat) & rosewood flamenco bridge
- Flamenco scratch plates
- Ortega 12hole bridge
- Fishman Clasica Blend preamp/pickup system
- 2way truss rod built-in
- D'Addario EXP46 strings
- Made in Spain
- FREE deluxe gig bag included





Thomas Zwijsen
Signature model/custom made

photo: Robert Hucko

**SPANISH HEEL
CUTAWAY/PICKUP**



scale: 650 mm
width at nut: 48 mm

TZSM

- Solid Canadian spruce top, gloss finish
- Red Gum back & side, satin finish
- Mahogany neck, satin finish
- Rosewood binding
- Ebony fretboard curved, 12" radius & rosewood bridge
- Ortega 6hole bridge, rosewood
- Fishman Clasica Blend preamp/pickup system
- 2way truss rod built-in
- D'Addario EXP46 strings
- Made in Spain
- FREE deluxe gig bag included





STAGE SERIES



The perfect transitional guitar for a steel string player who wants the nylon string sound. With an ultra slim neck and a radiused fretboard there is no need to adjust how you play.

STAGE SERIES YOUR OPTIONS

scales and sizes

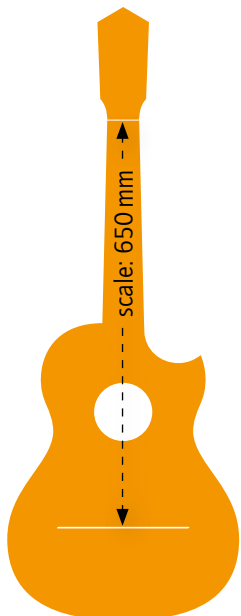

width at nut

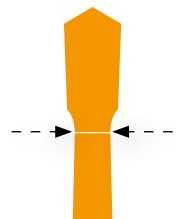

extra slim: 47 mm

wood variations: top



solid Canadian Sitka spruce



solid Canadian Engelmann spruce

wood variations: back & sides



paldao



flamed mahogany



walnut

electronics



Now with Fishman Clasica Blend Preamp

features



curved fretboard



14th fret heel to body connection



bag/strap

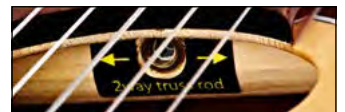

2way truss rod

strings

SAVAREZ

Savarez 510CJ strings



**FLORENTINE CUTAWAY/PICKUP
ORTEGA SIGNATURE ROSETTE**

scale: 650 mm
width at nut: 47 mm **EXTRA SLIM NECK**

CORAL



- Solid Canadian Sitka spruce top, satin finish
- Paldao (dao) back & side, satin finish
- Thinline body depth (90 mm)
- Walnut binding/white purfling
- Mahogany neck, satin finish
- 14th fret heel to body connection
- Curved (radius 400 mm - 15.75") acacia fretboard & acacia bridge
- Fishman Clasic Blend preamp/pickup system with built-in tuner
- 2way truss rod built-in
- Savarez 510CJ strings
- FREE deluxe gig bag & nylon strap included



**FLORENTINE CUTAWAY/PICKUP
ORTEGA SIGNATURE ROSETTE**

scale: 650 mm
width at nut: 47 mm **EXTRA SLIM NECK** **AGB** (antique grey black)

OPAL



- Solid Canadian Sitka spruce top, gloss finish
- Flamed mahogany back & side, gloss finish
- Thinline body depth (90 mm)
- Maple binding/green pearl ABS purfling
- Mahogany neck, satin finish, AGB
- 14th fret heel to body connection
- Curved (radius 400 mm - 15.75") acacia fretboard & acacia bridge
- Fishman Clasic Blend preamp/pickup system with built-in tuner
- 2way truss rod built-in
- Savarez 510CJ strings
- FREE deluxe gig bag, nylon strap & static pickguard included



**ALL SOLID
FLORENTINE CUTAWAY/PICKUP
ORTEGA SIGNATURE ROSETTE**

scale: 650 mm
width at nut: 47 mm **EXTRA SLIM NECK**

JADE



- Solid Canadian Engelmann spruce top, gloss finish
- Solid walnut back & side, gloss finish
- Thinline body depth (90 mm)
- Maple binding/green pearl ABS purfling
- Mahogany neck, satin finish
- 14th fret heel to body connection
- Curved (radius 400 mm - 15.75") acacia fretboard & acacia bridge
- Fishman Clasic Blend preamp/pickup system with built-in tuner
- 2way truss rod built-in
- Savarez 510CJ strings
- FREE deluxe gig bag, nylon strap & static pickguard included





THE PRIVATE ROOM

CUSTOM CRAFTED INSTRUMENTS

" The Private Room starts with handpicked tonewoods that are set aside to be custom crafted into exclusive guitars. Their selection is limited and truly unique. "

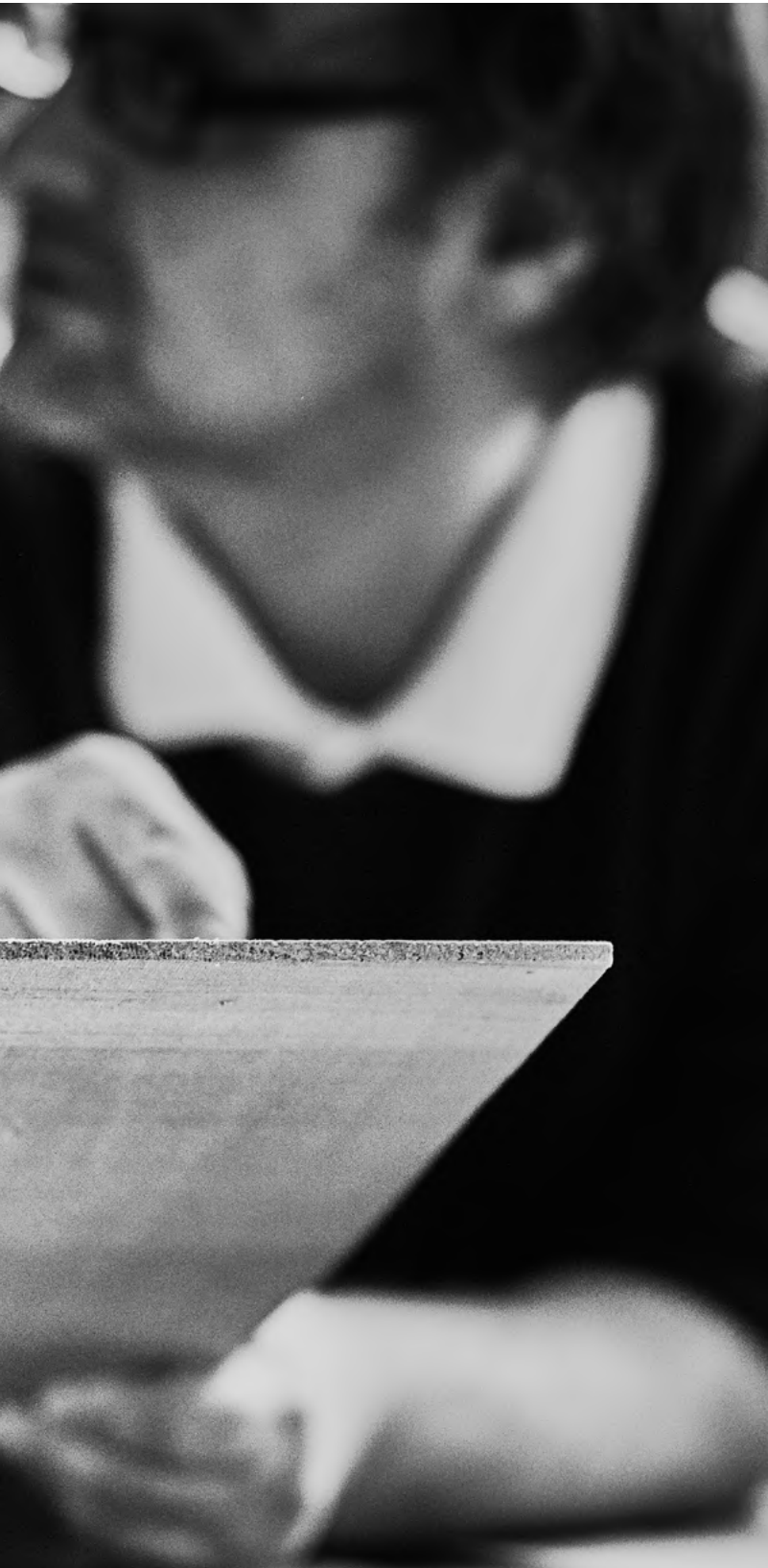

Index

Page

Stomp Boxes	004
Ukuleles & Gitarleles	010
Nylon String Guitars	042
★ The Private Room	092
Distressed Suites	094
Eclipse Suite	095
Striped Suites	096
Honey Suites	097
Acoustic Basses	098
Banjos	112
Mandolins	120
Percussion	126
Accessories	134



DISTRESSED SUITES

DS SUITE E art. DSSUITE-E



THINLINE BODY PICKUP



DISTRESSED SATIN FINISH

scale: 650 mm
width at nut: 48 mm

SN & DTS
(slim neck & distressed tobacco sunburst finish)



- Solid Alaska spruce top, DTS, satin finish
- Mahogany back & side, DTS, satin finish
- NO body binding, walnut fretboard binding
- Mahogany neck, distressed tobacco sunburst, satin
- Heel to body connection on 14th fret
- Blackwood fretboard (radius, 400R) with „XII“ inlay on 12th fret
- 2way truss rod
- Spanish heel
- Ortega signature walnut/maple/white pearl rosette
- Ortega 12hole bridge, walnut
- Aged vintage tuning machines, classic 3 bar
- Ortega MagusPro preamp/pickup system built-in
- Savarez 500CJ strings
- FREE gig bag & suede leather strap included

DS SUITE C/E art. DSSUITE-C/E



THINLINE BODY CUTAWAY/PICKUP



DISTRESSED SATIN FINISH

scale: 650 mm
width at nut: 48 mm

SN & DTS
(slim neck & distressed tobacco sunburst finish)



- Solid Alaska spruce top, DTS, stain finish
- Mahogany back & side, DTS, stain finish
- NO body binding, walnut fretboard binding
- Mahogany neck, distressed tobacco sunburst, satin
- Heel to body connection on 14th fret
- Blackwood fretboard (radius, 400R) with „XII“ inlay on 12th fret
- 2way truss rod
- Spanish heel
- Ortega signature walnut/maple/white pearl rosette
- Ortega 12hole bridge, walnut
- Aged vintage tuning machines, classic 3 bar
- Ortega MagusPro preamp/pickup system built-in
- Savarez 500CJ strings
- FREE gig bag & suede leather strap included

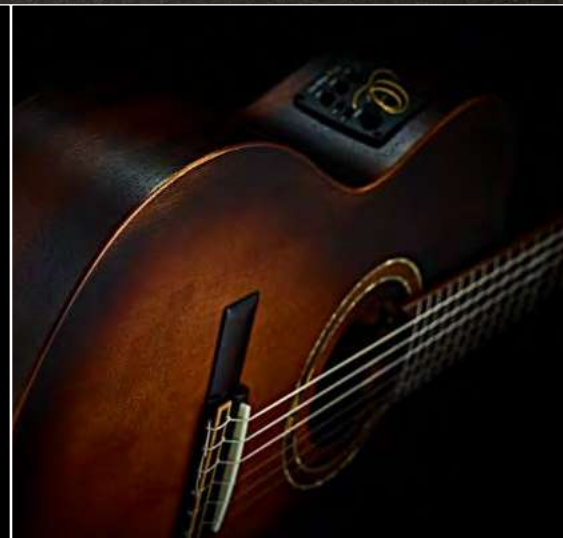

ECLIPSE SUITE

ECLIPSE SUITE C/E art. ECLIPSESU.C/E



**CUTAWAY/PICKUP
BUILT-IN ARMREST**



**FULL
MAHOGANY
MADE**

scale: 650 mm
width at nut: 48 mm

SN
(slim neck)



- Solid mahogany top, eclipse burst gloss finish
- Mahogany back & side, gloss finish
- Walnut top & bottom binding/ MOP purfling
- Walnut armrest
- Mahogany neck, gloss finish
- Blackwood fretboard (flat) & bridge
- 2 way truss rod
- Spanish heel
- Eclipse soundhole design
- Eclipse fretboard inlay
- Ortega 12hole bridge
- A class tuning machines matt brass/black
- Savarez 500CJ strings
- FREE gig bag & suede leather strap included





STRIPED SUITES

STRIPED SUITE art. STRIPEDSUITE



BUILT-IN ARMREST

**AAA STRIPED
EBONY
BACK & SIDE**

scale: 650 mm
width at nut: 50 mm

MN
(medium
neck)



- Solid Alaska spruce top, gloss finish
- AAA striped ebony back & side, gloss finish
- Acacia binding/white purfling
- Mahogany neck, gloss finish
- Blackwood fretboard (flat) & bridge
- 2way truss rod
- Spanish heel
- Ortega signature walnut/maple/white pearl rosette
- Ortega 12hole bridge
- A class tuning machines matt brass/black
- Savarez 500CJ strings
- FREE gig bag & suede leather strap included

STRIPED SUITE C/E art. STRIPEDSU.C/E



**CUTAWAY/PICKUP
BUILT-IN ARMREST**

**AAA STRIPED
EBONY
BACK & SIDE**

scale: 650 mm
width at nut: 48 mm

SN
(slim neck)



- Solid Alaska spruce top, gloss finish
- AAA striped ebony back & side, gloss finish
- Acacia binding/white purfling
- Mahogany neck, gloss finish
- Blackwood fretboard (flat) & bridge
- 2way truss rod
- Spanish heel
- Ortega signature walnut/maple/white pearl rosette
- Ortega 12hole bridge
- A class tuning machines matt brass/black
- Ortega MagusPro preamp/pickup system built-in
- Savarez 500CJ strings
- FREE gig bag & suede leather strap included

STRIPED SUITE ACB art. STRIPEDSU.ACB



**BUILT-IN ARMREST
4STRING ACOUSTIC BASS
CUTAWAY/PICKUP**

**AAA STRIPED
EBONY
BACK & SIDE**

medium scale: 812 mm (32")
width at nut: 45 mm (1.77")
body depth: 122 mm (4.8")



- 4 string acoustic bass
- Solid Alaska spruce top, gloss finish
- AAA striped ebony back & side, gloss finish
- Acacia top & bottom binding /white purfling
- Mahogany neck, gloss finish
- Medium scale
- Tecwood fretboard w/walnut binding
- Tecwood bridge
- 2way truss rod
- Ortega signature walnut/maple/white pearl rosette
- Ortega Die cast tuning machines, gold
- D'Addario EXPBBB 170 acoustic bass strings
- FREE gig bag & genuine leather strap included



HONEY SUITES

HONEY SUITE art. HONEYSUITE



HSB
(honey burst)

**AAA FLAMED
MAPLE
BACK & SIDE**

scale: 650 mm
width at nut: 50 mm

MN
(medium
neck)



- Solid Alaska spruce top, honey burst gloss finish
- AAA flamed maple back & side, honey burst gloss finish
- Flamed maple binding/white purfling
- Maple neck, honey burst gloss finish
- Blackwood fretboard (flat) & bridge
- 2way truss rod
- Spanish heel
- Ortega signature walnut/maple/white pearl rosette
- Ortega 12hole bridge
- A class tuning machines matt brass/black
- Savarez 500CJ strings
- FREE gig bag & suede leather strap included

HONEY SUITE C/E art. HONEYSUITEC/E



CUTAWAY/PICKUP

HSB
(honey burst)

**AAA FLAMED
MAPLE
BACK & SIDE**

scale: 650 mm
width at nut: 48 mm

SN
(slim neck)



- Solid Alaska spruce top, honey burst gloss finish
- AAA flamed maple back & side, honey burst gloss finish
- Flamed maple binding/white purfling
- Maple neck, honey burst gloss finish
- Blackwood fretboard (flat) & bridge
- 2way truss rod
- Spanish heel
- Ortega signature walnut/maple/white pearl rosette
- Ortega 12hole bridge
- A class tuning machines matt brass/black
- Ortega MagusPro preamp/pickup system built-in
- Savarez 500CJ strings
- FREE gig bag & suede leather strap included



ACOUSTIC BASSES



Index

Page

Stomp Boxes	004
-------------	-----

Ukuleles & Guitarleles	010
------------------------	-----

Nylon String Guitars	042
----------------------	-----

★ The Private Room	092
--------------------	-----

Acoustic Basses	098
------------------------	------------

Lizard Series	102
---------------	-----

Deep Traveler Series	104
----------------------	-----

Deep Series 5	105
---------------	-----

Deep Series 3	106
---------------	-----

Deep Series 2	107
---------------	-----

Signature Series	108
------------------	-----

Banjos	112
--------	-----

Mandolins	120
-----------	-----

Percussion	126
------------	-----

Accessories	134
-------------	-----



LIZARD SERIES
DEEP
TRAVELER SERIES
DEEP SERIES **532**
SIGNATURE
SERIES

With a diverse selection of Acoustic Bases you're sure to find what you need. From our 4 and 5string models with either medium or long scale options, to our Ukebass and Traveler series, all with electronics. We have you covered.

ALL ACOUSTIC BASS SERIES

YOUR OPTIONS

scales and sizes

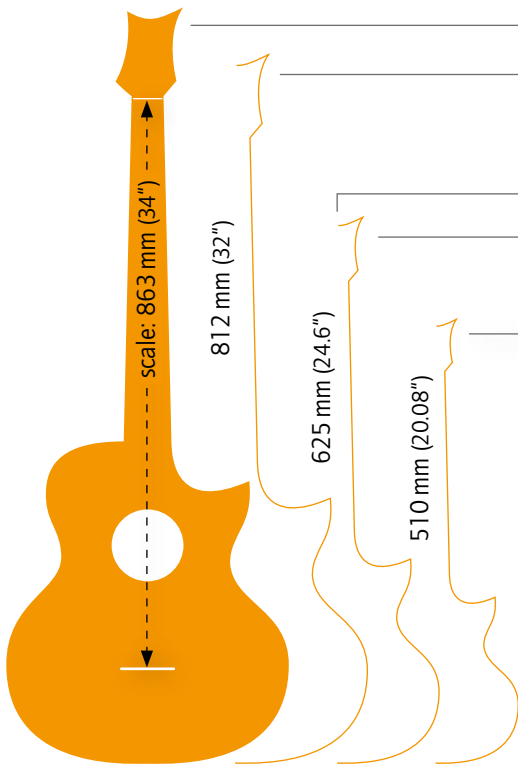

LONG SCALE

MEDIUM SCALE

PM-SHAMAN

TRAVELER

LIZARD

width at nut

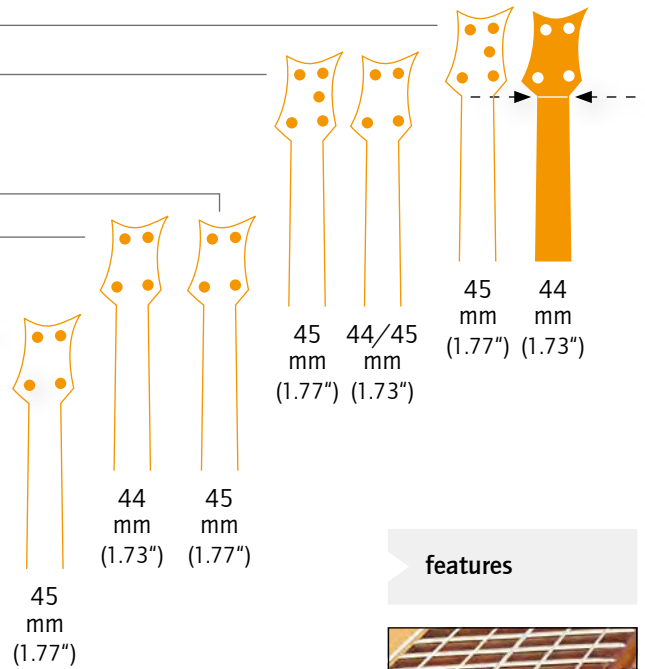

features



2way truss rod

lefthand



bag/strap

wood variations: top



wood variations: back & sides



color/finish variations

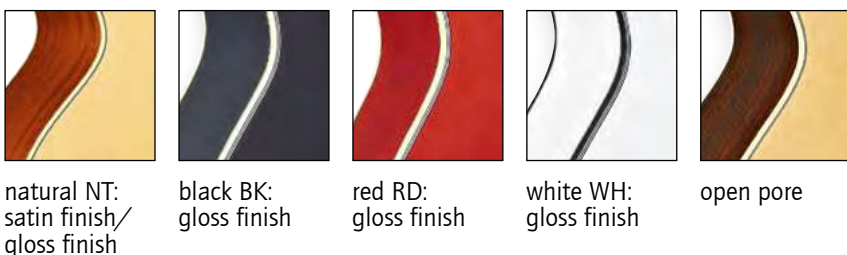

body



strings

D'Addario

D'Addario EXPPBB170, D'Addario EXPPBB170-5

ORTEGA®

Ortega ODW-4



Aquila Thundergut long/short scale

electronics

Fishman Isys+/Presys+/Ortega Magus Uke Bass/Ortega MagusPro Bass/B-Band A1.2



LIZARD SERIES



PICKUP

scale: 510 mm (20.08")
width at nut: 45 mm (1.77")



LIZZY-BS-GB



- Mahogany top, satin finish
- Mahogany back & side, satin finish
- Mahogany neck, satin finish
- Walnut fretboard & bridge
- Black ABS binding/white purfling
- Ortega MagusUkebass preamp/pickup system
- 15 frets
- 2way truss rod built-in
- Aquila Thundergut Ukebass 68U strings, short scale
- FREE deluxe gig bag & nylon strap incl.



PICKUP

LINED FRETLESS

scale: 510 mm (20.08")
width at nut: 45 mm (1.77")



LIZZY-BSFL-GB



- Mahogany top, satin finish
- Mahogany back & side, satin finish
- Mahogany neck, satin finish
- Walnut fretboard & bridge
- Black ABS binding/white purfling
- Ortega MagusUkebass preamp/pickup system
- 2way truss rod built-in
- Aquila Thundergut Ukebass 68U strings, short scale
- FREE deluxe gig bag & nylon strap incl.

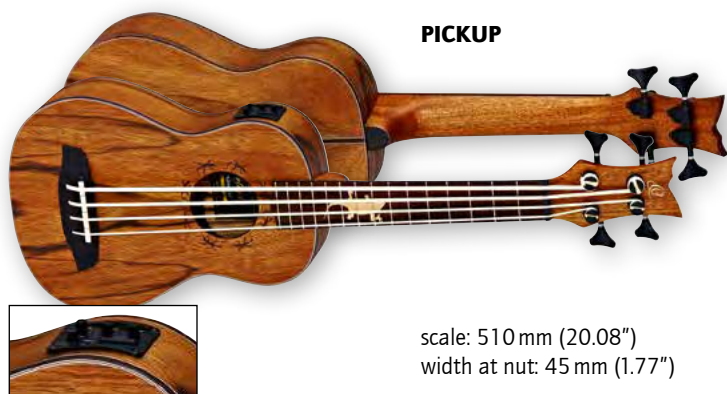

PICKUP

scale: 510 mm (20.08")
width at nut: 45 mm (1.77")



LIZARD-BS-GB



- Dao top, satin finish
- Dao back & side, satin finish
- Mahogany neck, satin finish
- Walnut fretboard & bridge
- Black ABS binding/white purfling
- Ortega MagusUkebass preamp/pickup system
- 15 frets
- 2way truss rod built-in
- Aquila Thundergut Ukebass 68U strings, short scale
- FREE deluxe gig bag & nylon strap incl.

CAIMAN-BS-GB



CUTAWAY/PICKUP



ARCHED BACK scale: 510 mm (20.08")
width at nut: 45 mm (1.77")



- Acacia top, gloss finish
- Acacia back (arched) & side, gloss finish
- Mahogany neck, gloss finish
- Walnut fretboard & bridge
- Mahogany body & fretboard binding
- Abalone style purfling
- Mahogany dot fretboard inlays
- Ortega Magus Ukebass preamp/pickup system
- 2way truss rod built-in
- Custom made indirect Ukebass tuning machines, black
- Aquila Thundergut Ukebass 68U strings, short scale
- FREE deluxe gig bag & nylon strap incl.

CAIMAN-FL-GB



CUTAWAY/PICKUP
LINED FRETLESS



ARCHED BACK scale: 510 mm (20.08")
width at nut: 45 mm (1.77")



- Acacia top, gloss finish
- Acacia back (arched) & side, gloss finish
- Mahogany neck, gloss finish
- Walnut fretboard & bridge
- Mahogany body & fretboard binding
- Abalone style purfling
- Mahogany dot fretboard inlays/lines
- Ortega Magus Ukebass preamp/pickup system
- 2way truss rod built-in
- Custom made indirect Ukebass tuning machines, black
- Aquila Thundergut Ukebass 68U strings, short scale
- FREE deluxe gig bag & nylon strap incl.





DEEP TRAVELER SERIES



CUTAWAY/PICKUP



scale: 625 mm (24.60")
width at nut: 44 mm (1.73")

BK
(black)

D-WALKER-BK



- Agathis top, gloss finish black
- Agathis back & side, gloss finish black
- Mahogany neck, gloss finish black
- Acacia fretboard & bridge
- Ivory ABS binding
- B.Band A1.2 preamp/pickup system
- 19 frets
- 2way truss rod built-in
- Ortega ODW-4 strings
- FREE deluxe gig bag & nylon strap incl.



CUTAWAY/PICKUP



scale: 625 mm (24.60")
width at nut: 44 mm (1.73")

RD
(red)

D-WALKER-RD



- Agathis top, gloss finish red
- Agathis back & side, gloss finish red
- Mahogany neck, gloss finish red
- Acacia fretboard & bridge
- Ivory ABS binding
- B.Band A1.2 preamp/pickup system
- 19 frets
- 2way truss rod built-in
- Ortega ODW-4 strings
- FREE deluxe gig bag & nylon strap incl.



CUTAWAY/PICKUP



scale: 625 mm (24.60")
width at nut: 44 mm (1.73")

WH
(white)

D-WALKER-WH



- Agathis top, gloss finish white
- Agathis back & side, gloss finish white
- Mahogany neck, gloss finish white
- Acacia fretboard & bridge
- Black ABS binding
- B.Band A1.2 preamp/pickup system
- 19 frets
- 2way truss rod built-in
- Ortega ODW-4 strings
- FREE deluxe gig bag & nylon strap incl.



CUTAWAY/PICKUP



scale: 625 mm (24.60")
width at nut: 44 mm (1.73")

MM
(mahogany)

D-WALKER-MM



- Mahogany top, gloss finish
- Mahogany back & side, gloss finish
- Mahogany neck, gloss finish
- Acacia fretboard & bridge
- Black ABS binding
- B.Band A1.2 preamp/pickup system
- 19 frets
- 2way truss rod built-in
- Ortega ODW-4 strings
- FREE deluxe gig bag & nylon strap incl.

DEEP SERIES 5 SOLID SPRUCE TOP – OPEN PORE

ortegaguitars.com

105

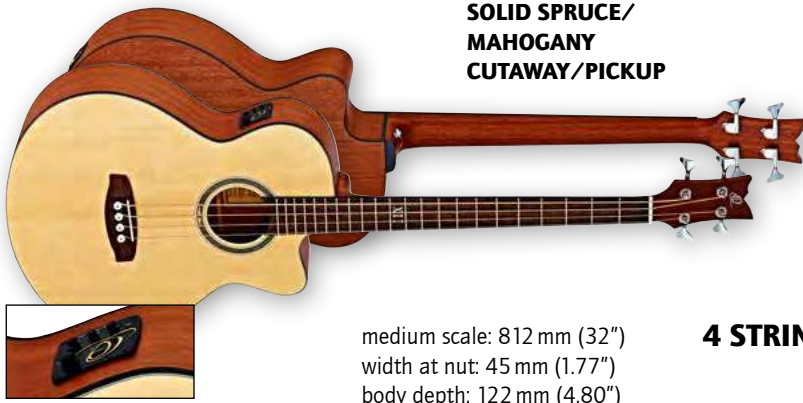

**SOLID SPRUCE/
MAHOGANY
CUTAWAY/PICKUP**

D538-4

medium scale: 812 mm (32")
width at nut: 45 mm (1.77")
body depth: 122 mm (4.80")

4 STRING

- Solid Alaska spruce top, satin finish
- Sapele back & side, open pore
- Mahogany neck, open pore
- Tecwood fretboard w/black ABS binding
- Tecwood bridge
- Black ABS binding/bk-wh-bk purfling
- Chrome hardware
- ORTEGA MagusPro BASS preamp/pickup system
- 2way truss rod built-in
- D'Addario EXPPBB170 acoustic bass strings

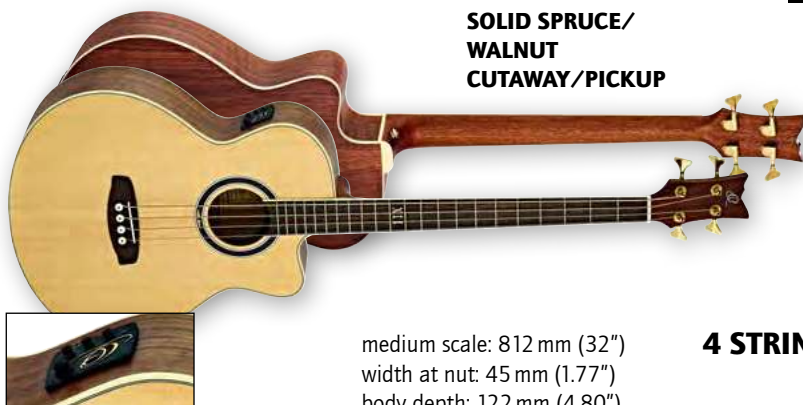

**SOLID SPRUCE/
WALNUT
CUTAWAY/PICKUP**

D558-4

medium scale: 812 mm (32")
width at nut: 45 mm (1.77")
body depth: 122 mm (4.80")

4 STRING

- Solid Alaska spruce top, satin finish
- Walnut back & side, open pore
- Mahogany neck, open pore
- Tecwood fretboard w/black ABS binding
- Tecwood bridge
- Ivory ABS binding/bk-wh-bk purfling
- Gold hardware
- ORTEGA MagusPro BASS preamp/pickup system
- 2way truss rod built-in
- D'Addario EXPPBB170 acoustic bass strings





DEEP SERIES 3 PALDAO



**4STRING
CUTAWAY/PICKUP**

LONGSCALE

scale: 863 mm (34")
width at nut: 44 mm (1.73")
body depth: 126 mm (4.96")

D3C-4



- Paldao (dao) top, gloss finish
- Paldao (dao) back & side, gloss finish
- Mahogany neck, gloss finish
- Acacia fretboard & bridge
- Walnut binding/white purfling
- Black hardware
- Fishman Isis+ preamp/pickup system
- 2way truss rod built-in
- D'Addario EXPPBB170 strings
- FREE deluxe gig bag, genuine leather strap & straplock pins included

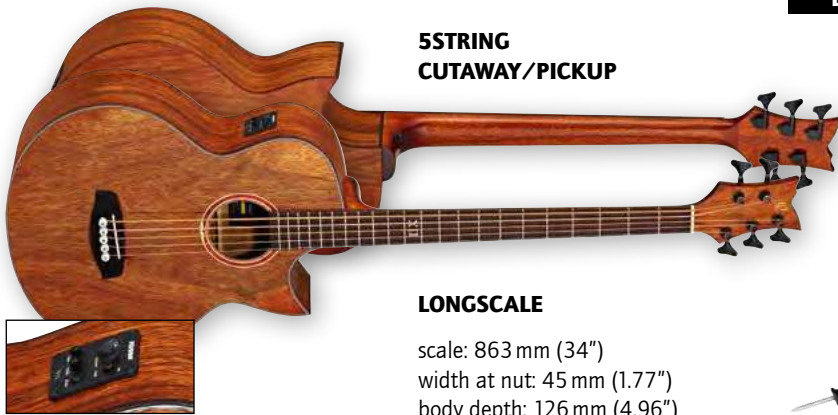

**5STRING
CUTAWAY/PICKUP**

LONGSCALE

scale: 863 mm (34")
width at nut: 45 mm (1.77")
body depth: 126 mm (4.96")

D3C-5



- Paldao (dao) top, gloss finish
- Paldao (dao) back & side, gloss finish
- Mahogany neck, gloss finish
- Acacia fretboard & bridge
- Walnut binding/white purfling
- Black hardware
- Fishman Isis+ preamp/pickup system
- 2way truss rod built-in
- D'Addario EXPPBB170-5 strings
- FREE deluxe gig bag, genuine leather strap & straplock pins included

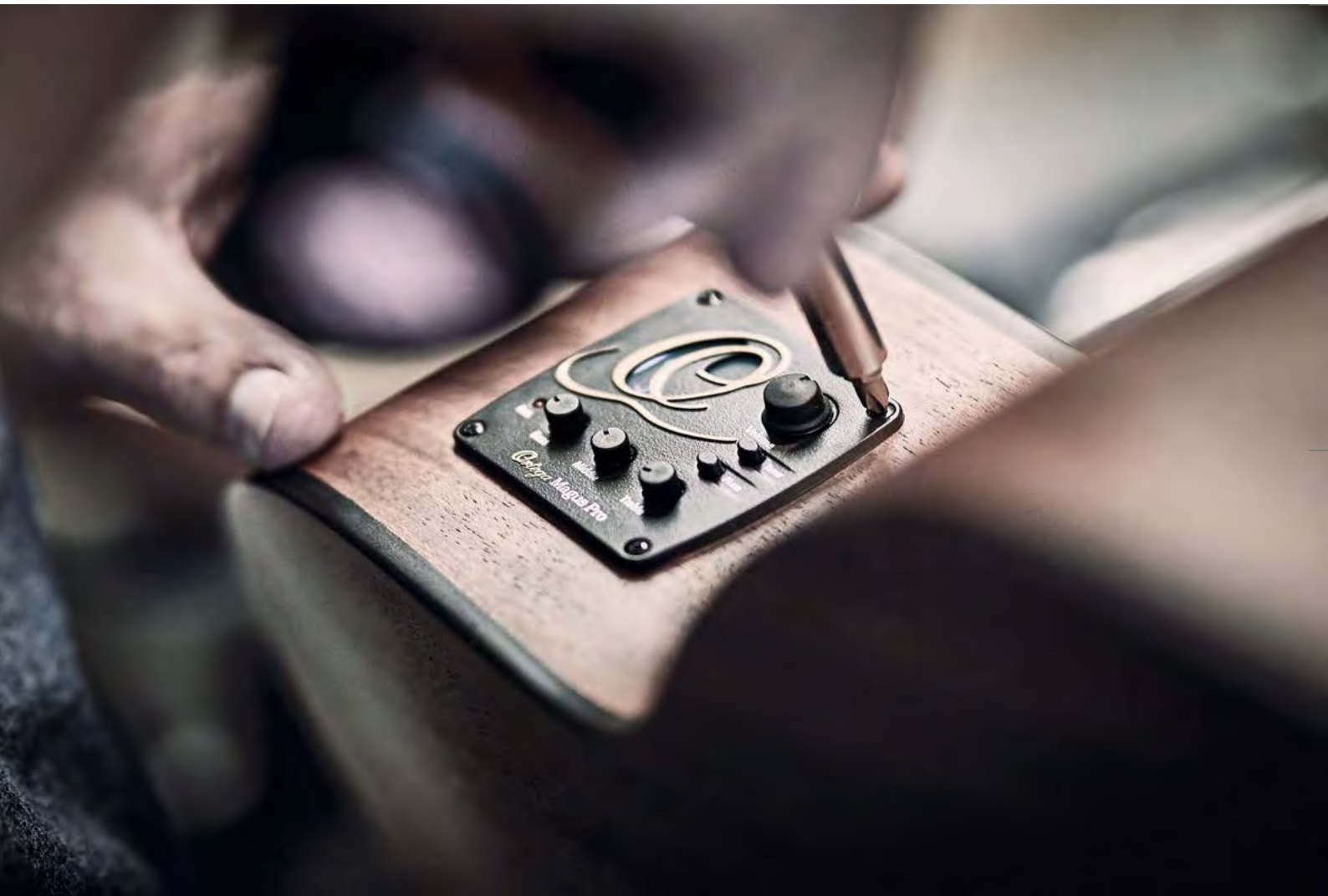

DEEP SERIES 2

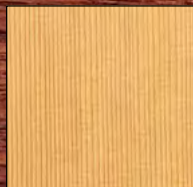

SOLID CEDAR TOP



**4STRING
CUTAWAY/PICKUP**

medium scale: 812 mm (32")
width at nut: 44 mm (1.73")
body depth: 126 mm (4.96")

D2-4



- Solid North American cedar top, satin finish
- Walnut back & side, satin finish
- Mahogany neck, satin finish
- Acacia fretboard & bridge
- Maple binding /ABS pearl purfling
- Gold hardware
- Fishman Presys+ preamp/pickup system
- 2way truss rod built-in
- D'Addario EXPPBB170 strings
- FREE deluxe gig bag, genuine leather strap & straplock pins included



**FRETLESS
4STRING
CUTAWAY/PICKUP**

medium scale: 812 mm (32")
width at nut: 44 mm (1.73")
body depth: 126 mm (4.96")

D2-4FL



- Solid North American cedar top, satin finish
- Walnut back & side, satin finish
- Mahogany neck, satin finish
- Acacia fretboard & bridge
- Maple binding /ABS pearl purfling
- Gold hardware
- Fishman Presys+ preamp/pickup system
- 2way truss rod built-in
- D'Addario EXPPBB170 strings
- FREE deluxe gig bag, genuine leather strap & straplock pins included



**5STRING
CUTAWAY/PICKUP**

medium scale: 812 mm (32")
width at nut: 44 mm (1.73")
body depth: 126 mm (4.96")

D2-5



- Solid North American cedar top, satin finish
- Walnut back & side, satin finish
- Mahogany neck, satin finish
- Acacia fretboard & bridge
- Maple binding /ABS pearl purfling
- Gold hardware
- Fishman Presys+ preamp/pickup system
- 2way truss rod built-in
- D'Addario EXPPBB170-5 strings
- FREE deluxe gig bag, genuine leather strap & straplock pins included



SIGNATURE SERIES

I'm proud to have my name on it!
Ken Taylor





**4STRING
CUTAWAY/PICKUP**

LONGSCALE

scale: 863 mm (34")
width at nut: 44 mm (1.73")
body depth: 126 mm (4.96")

KTSM-4



- Solid North American spruce top, gloss finish
- Flamed mahogany back & side, gloss finish
- Mahogany neck, gloss finish
- Acacia fretboard & bridge
- Custom designed Fretboard inlays
- Walnut binding/white purfling
- Black hardware
- Fishman Presys+ preamp/pickup system
- 2way truss rod built-in
- D'Addario EXPBBB170 strings
- FREE deluxe gig bag, genuine leather strap & straplock pins included



**5STRING
CUTAWAY/PICKUP**

LONGSCALE

scale: 863 mm (34")
width at nut: 45 mm (1.77")
body depth: 126 mm (4.96")

KTSM-5



- Solid North American spruce top, gloss finish
- Flamed mahogany back & side, gloss finish
- Mahogany neck, gloss finish
- Acacia fretboard & bridge
- Custom designed Fretboard inlays
- Walnut binding/white purfling
- Black hardware
- Fishman Presys+ preamp/pickup system
- 2way truss rod built-in
- D'Addario EXPBBB170-5 strings
- FREE deluxe gig bag, genuine leather strap & straplock pins included



**LINED FRETLESS
5STRING
CUTAWAY/PICKUP**

LONGSCALE

scale: 863 mm (34")
width at nut: 45 mm (1.77")
body depth: 126 mm (4.96")

KTSM-5FL



- Solid North American spruce top, gloss finish
- Flamed mahogany back & side, gloss finish
- Mahogany neck, gloss finish
- Acacia fretboard & bridge
- Custom designed fretboard inlays
- Walnut binding/white purfling
- Black hardware
- Fishman Presys+ preamp/pickup system
- 2way truss rod built-in
- D'Addario EXPBBB170-5 strings
- FREE deluxe gig bag, genuine leather strap & straplock pins included





SIGNATURE SERIES



My PM-SHAMAN looks small but it sounds very BIG!!! I call it "Shaman Bass". Proud to be with great Ortega family! Pawel "Stirwater" Maciwoda - THE SCORPIONS



**LINED FRETLESS
4STRING
CUTAWAY/PICKUP**

scale: 625 mm (24.60")
width at nut: 45 mm (1.77")

PM-SHAMAN



- SOLID mahogany top, satin finish
- Mahogany back & side, satin finish
- Mahogany neck, satin finish
- Acacia fretboard & bridge
- Black ABS binding/white purfling
- Lasered Lizard rosette
- Ortega MagusUkebass preamp/pickup system
- 2way truss rod built-in
- AQUILA Thundergut Ukebass strings/long scale
- FREE deluxe gig bag & nylon strap incl.



Production: THE SCORPIONS - MTV unplugged
City: COLOGNE, Germany
Venue: ARENA
Gear: 2 x PM-SHAMAN CUSTOMIZED, 4 x KTSM-5, 1 x LIZARD-BS-GB





BANJOS



Index

Page

Stomp Boxes	004
Ukuleles & Guitarleles	010
Nylon String Guitars	042
★ The Private Room	092
Acoustic Basses	098

Banjos 112

Raven Series	114
Falcon Series	117

Mandolins	120
Percussion	126
Accessories	134



RAVEN SERIES

Breaking tradition we add a fresh look to a familiar instrument. From our Ukulele-Banjo, Guitar Banjo and the Standard 5string models all have black Banjo heads and a modern headstock to stand apart from the crowd.



OUBJ100-SBK



- 4string Ukulele-Banjo
- Hard maple neck
- Maple plywood resonator
- Ovangkol fretboard
- Maple plywood rim
- 18 brackets
- Chrome hardware
- Remo ebony head, black
- Open geared machine head
- D'Addario J92 Pro-Arte Ukulele strings, Concert
- FREE deluxe Banjo bag included

OBJ250-SBK



- 5string Banjo
- Mahogany neck
- Mahogany resonator
- Ovangkol fretboard
- Mahogany plywood rim
- 24 brackets
- Chrome hardware
- Remo ebony head, black
- Die cast machine head
- D'Addario J60 5string Banjo, Nickel Light, 9-20
- FREE deluxe Banjo bag included

OBJ250OP-SBK



- 5string Banjo, OPEN BACK
- Mahogany neck
- Ovangkol fretboard
- Mahogany plywood rim
- 24 brackets
- Chrome hardware
- Remo ebony head, black
- Die cast machine head
- D'Addario J60 5string Banjo, Nickel Light, 9-20
- FREE deluxe Banjo bag included

OBJE250OP-SBK

**BUILT-IN PICKUP SYSTEM/
W. VOLUME CONTROL**



- 5string Banjo, OPEN BACK
- Mahogany neck
- Ovangkol fretboard
- Mahogany plywood rim
- 24 brackets
- Chrome hardware
- Remo ebony head, black
- Die cast machine head
- D'Addario J60 5string Banjo, Nickel Light, 9-20
- FREE deluxe Banjo bag included



OBJ350/6-SBK

- 6string Guitar Banjo
- Mahogany neck
- Mahogany resonator
- Ovangkol fretboard
- Aluminum rim
- Chrome armrest, Ortega engraved
- 30 brackets
- Chrome hardware
- Remo ebony head, black
- Die cast machine head
- D'Addario .012 -.053 strings
- FREE deluxe Banjo bag included



**BUILT-IN PICKUP SYSTEM/
W. VOLUME CONTROL**

OBJE350/6-SBK

- 6string Guitar Banjo
- Mahogany neck
- Mahogany resonator
- Ovangkol fretboard
- Aluminum rim
- Chrome armrest, Ortega engraved
- 30 brackets
- Chrome hardware
- Remo ebony head, black
- Die cast machine head
- D'Addario .012 -.053 strings
- FREE deluxe Banjo bag included



OBJ450-SBK

- 5string Banjo
- Mahogany neck
- Mahogany resonator
- Rosewood fretboard
- Mahogany plywood rim
- 24 brackets
- Chrome hardware
- Remo ebony head, black
- Rolled brass tone ring
- Geared machine head
- D'Addario J60 5string Banjo, Nickel Light, 9-20
- FREE deluxe Banjo bag included



OBJ650-SBK

- 5string Banjo
- Mahogany neck
- Mahogany resonator
- Rosewood fretboard
- 3ply solid maple rim
- Chrome armrest, Ortega engraved
- 24 brackets
- One piece flange
- Chrome hardware
- Remo ebony head, black
- Zinc alloy tone ring
- Die cast machine head
- D'Addario J60 5string Banjo, Nickel Light, 9-20
- FREE deluxe Banjo bag included





FALCON SERIES

Rooted in history, these Banjos are made with brass tone rings and beautiful Burl Walnut or Flamed Maple resonators for a brighter, crisper sound and more volume.



SATIN FINISH

OBJ550W-SNT



- 5string Banjo
- Walnut neck
- Burl walnut resonator
- Rosewood fretboard
- Walnut ply rim
- Chrome armrest, Ortega engraved
- 24 brackets
- Flat flange
- Chrome hardware
- Remo head, renaissance
- Rolled brass tone ring
- Geared machine head
- D'Addario J60 5string Banjo, Nickel Light, 9-20
- FREE deluxe Banjo bag included



**SATIN FINISH
4STRING**

OBJ550WTE-SNT



- 4string Banjo TENOR
- Walnut neck
- Burl walnut resonator
- Rosewood fretboard
- Walnut ply rim
- Chrome armrest, Ortega engraved
- 24 brackets
- Flat flange
- Chrome hardware
- Remo head, renaissance
- Rolled brass tone ring
- Geared machine head
- Satin finished natural walnut
- D'Addario J63i Irish Tenor Banjo, Nickel, 12-36
- FREE deluxe Banjo bag included



OBJ750-MA



- 5string Banjo
- Hard maple neck
- Flamed maple resonator
- Rosewood fretboard
- 3ply solid maple rim
- Chrome armrest, Ortega engraved
- 24 brackets
- One piece flange
- Chrome hardware
- Remo head, coated
- Brass tone ring
- Geared machine head
- Natural gloss on maple
- D'Addario J60 5string Banjo, Nickel Light, 9-20
- FREE deluxe Banjo bag included



**ELABORATELY CARVED HEEL
AND HEADSTOCK**

OBJ850-MA



- 5string Banjo
- Hard maple neck
- Flamed maple resonator
- Rosewood fretboard
- 3ply solid maple rim
- Golden armrest, Ortega engraved
- 24 brackets
- One piece flange
- Golden hardware
- Remo head, Weatherking clear
- Brass tone ring
- Geared machine head
- Gloss on flamed maple
- D'Addario J60 5string Banjo, Nickel Light, 9-20
- FREE deluxe Banjo bag included

OBJ950-FMA

- 5string Banjo ALL FLAMED MAPLE
- Flamed maple neck
- Flamed maple resonator
- Ebony fretboard
- 3ply solid maple rim
- Golden armrest, Ortega engraved
- 24 brackets
- One piece flange
- Golden hardware
- Remo head, coated
- Brass tone ring
- Geared machine head
- Gloss on all flamed maple
- D'Addario J60 5string Banjo, Nickel Light, 9-20
- FREE deluxe Banjo bag included





MANDOLINS

**Index****Page**

Stomp Boxes	004
Ukuleles & Gitarleles	010
Nylon String Guitars	042
★ The Private Room	092
Acoustic Basses	098
Banjos	112

Mandolins 120

A-Style Series	122
F-Style Series	124

Percussion	126
------------	-----

Accessories	134
-------------	-----



A-STYLE F-STYLE SERIES

Following in the American archetype of craftsmanship.
We offer our twist to the A-style and F-style mandolins.

RMA5NA



scale: 345 mm (13.58")
width at nut: 28 mm (1.10")

NA
(natural)

- Mahogany top, open pore satin finish
- Mahogany back (arched) & side, open pore satin finish
- Mahogany neck, satin finish
- Ovangkol fretboard & bridge
- 2way truss rod
- 20 frets
- D'Addario EXP74 strings

RMA5VS



scale: 345 mm (13.58")
width at nut: 28 mm (1.10")

VS
(vintage sunburst)

- Mahogany top, open pore vintage sunburst satin finish
- Mahogany back (arched) & side, open pore vintage sunburst satin finish
- Mahogany neck, satin finish
- Ovangkol fretboard & bridge
- 2way truss rod
- 20 frets
- D'Addario EXP74 strings

RMAE4OSBK

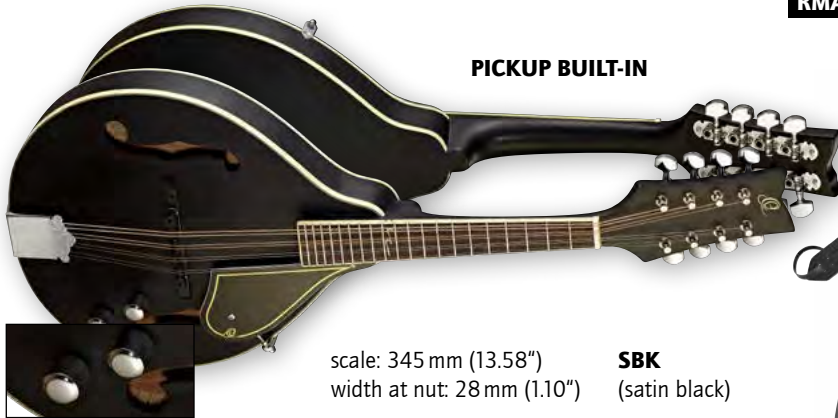

PICKUP BUILT-IN

scale: 345 mm (13.58")
width at nut: 28 mm (1.10")

SBK
(satin black)



- Spruce top, satin finish black
- Maple back (arched) & side, satin finish black
- Maple neck, satin finish black
- Rosewood fretboard & bridge
- 2way truss rod
- 20 frets
- Piezo bridge with tone & volume control, passive
- D'Addario EXP74 strings
- FREE deluxe gig bag & Mandolin strap included

RMA5OVY



scale: 345 mm (13.58")
width at nut: 28 mm (1.10")

VY
(vintage yellow)



- Spruce top, gloss finished vintage yellow
- Maple back (arched) & side, gloss finished vintage yellow
- Maple neck, gloss finished vintage yellow
- Ovangkol fretboard & bridge
- 2way truss rod
- 20 frets
- One piece die cast tailpiece, chrome
- D'Addario EXP74 strings
- FREE deluxe gig bag & Mandolin strap included



F-STYLE SERIES



PICKUP BUILT-IN

scale: 345 mm (13.58")
width at nut: 28 mm (1.10")

SBK
(satin black)

RMFE40SBK



- Spruce top, satin finish black
- Maple back (arched) & side, satin finish black
- Maple neck, satin finish black
- Rosewood fretboard & bridge
- 2way truss rod
- 24 frets
- Piezo bridge with tone & volume control, passive
- D'Addario EXP74 strings
- FREE deluxe gig bag & Mandolin strap included



scale: 345 mm (13.58")
width at nut: 28 mm (1.10")

VY
(vintage yellow)

RMF50VY



- Spruce top, gloss finished vintage yellow
- Maple back (arched) & side, gloss finished vintage yellow
- Maple neck, gloss finished vintage yellow
- Rosewood fretboard & bridge
- 2way truss rod
- 24 frets
- One piece die cast tailpiece, chrome
- D'Addario EXP74 strings
- FREE deluxe gig bag & Mandolin strap included

SOLID TOP



scale: 345 mm (13.58")
width at nut: 28 mm (1.10")

TS
(tobacco sunburst)

RMF90TS



- Solid spruce top, gloss tobacco sunburst finished
- Maple back (arched) & side, gloss tobacco sunburst finished
- Maple neck, gloss tobacco sunburst finished
- Rosewood fretboard & ebony bridge
- 2way truss rod
- 24 frets
- One piece die cast tailpiece, gold
- D'Addario EXP74 strings
- FREE deluxe gig bag & Mandolin strap included

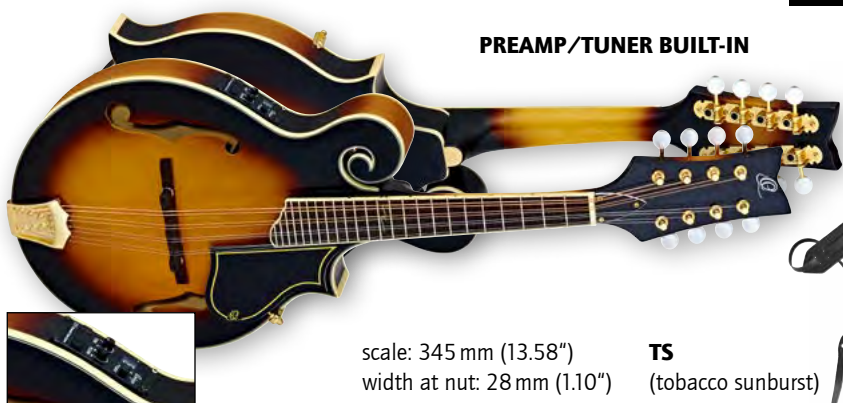

PREAMP/TUNER BUILT-IN

scale: 345 mm (13.58")
width at nut: 28 mm (1.10")

TS
(tobacco sunburst)

RMFE90TS



- Solid spruce top, gloss tobacco sunburst finished
- Maple back (arched) & side, gloss tobacco sunburst finished
- Maple neck, gloss tobacco sunburst finished
- Rosewood fretboard & ebony bridge
- Ortega SIT preamp/pickup system with built-in tuner
- 2way truss rod
- 24 frets
- One piece die cast tailpiece, gold
- D'Addario EXP74 strings
- FREE deluxe gig bag & Mandolin strap included



scale: 345 mm (13.58")
width at nut: 28 mm (1.10")

AVO
(antique violin oil)

RMF100AVO



- Solid distressed spruce top, antique violin oil
- Flamed maple back (arched) & side, distressed antique violin oil
- Maple neck, gloss tobacco sunburst finished
- Ebony fretboard & ebony bridge
- 2way truss rod
- 24 frets
- One piece die cast tailpiece, gold
- Grover tuning machines
- D'Addario EXP74 strings
- FREE deluxe gig bag & Mandolin strap included



PREAMP/TUNER BUILT-IN

scale: 345 mm (13.58")
width at nut: 28 mm (1.10")

AVO
(antique violin oil)

RMFE100AVO



- Solid distressed spruce top, antique violin oil
- Solid flamed maple back (arched) & side, distressed antique violin oil
- Maple neck, gloss tobacco sunburst finished
- Ebony fretboard & ebony bridge
- Ortega S1T preamp/pickup system with built-in tuner
- 2way truss rod
- 24 frets
- One piece die cast tailpiece, gold
- Grover tuning machines
- D'Addario EXP74 strings
- FREE deluxe gig bag & Mandolin strap included





PERCUSSION

ORTEGA
GUITARS • EST 1994



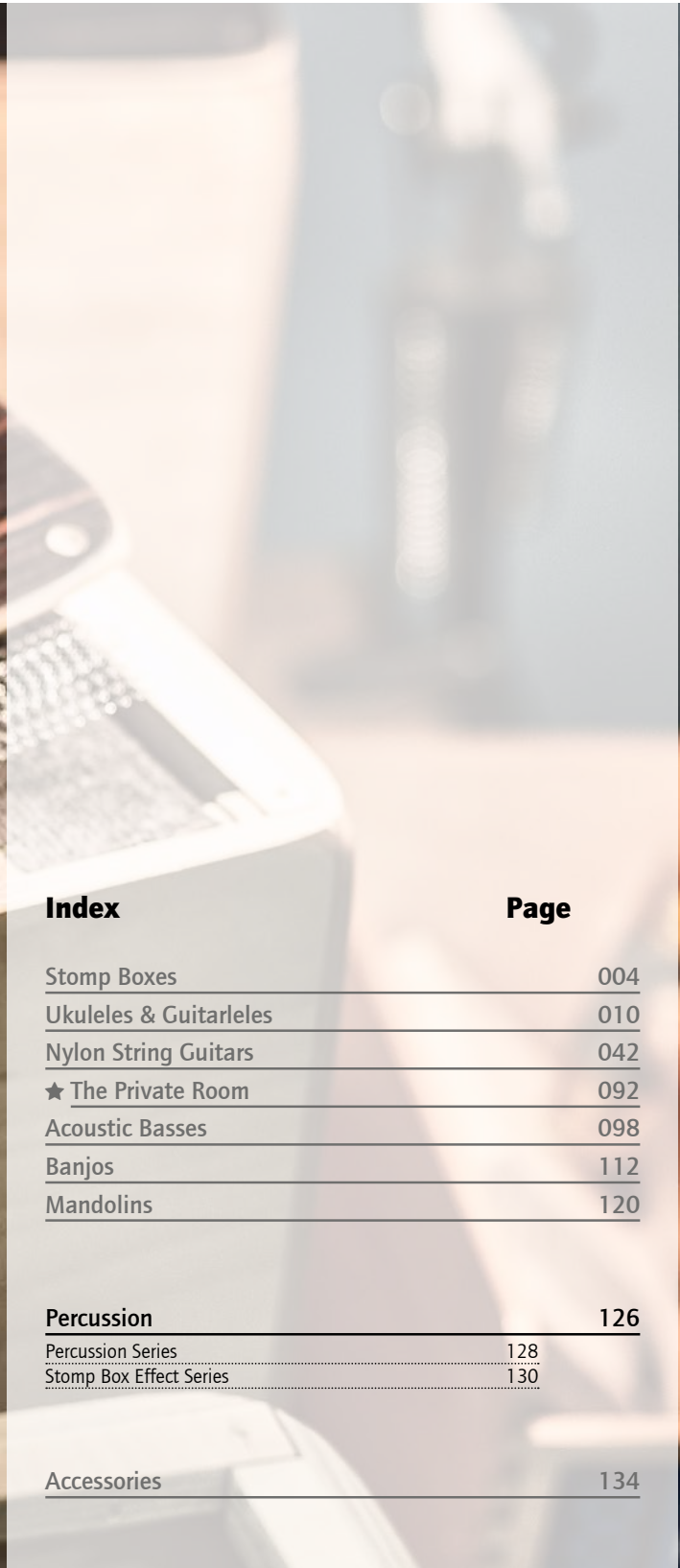
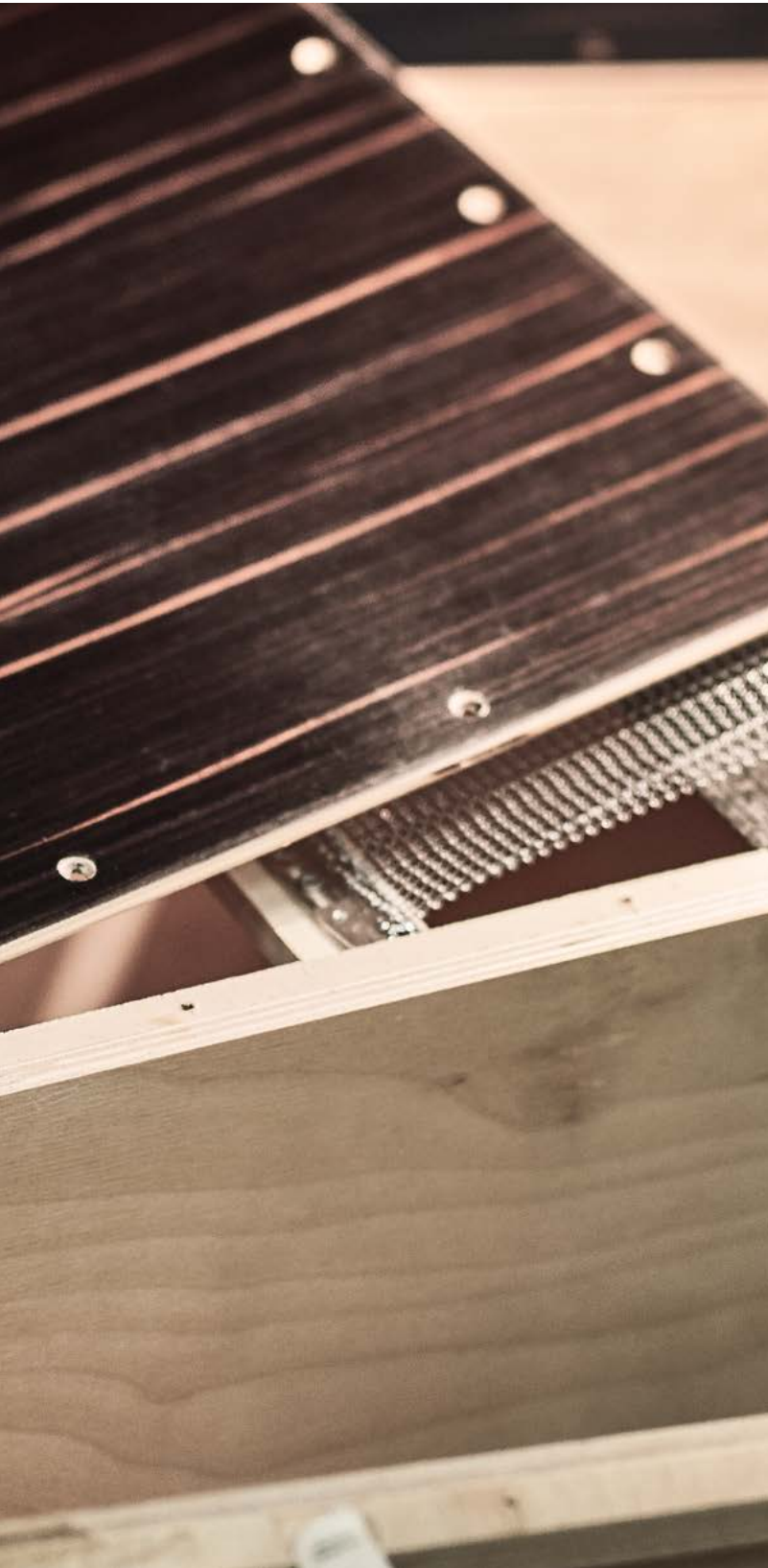

Index

Page

Stomp Boxes	004
Ukuleles & Guitarleles	010
Nylon String Guitars	042
★ The Private Room	092
Acoustic Basses	098
Banjos	112
Mandolins	120
Percussion	126
Percussion Series	128
Stomp Box Effect Series	130
Accessories	134



PERCUSSION SERIES

STOMP BOX CAJON BUNDLE

The Cajon - a quick excursion into its history: The Cajon originated from wooden crates that were used for the purpose of transporting food goods such as flour, fish, meat, vegetables and fruits. The Cajon has origins in Peru. The lack of drums forced poor people to play rhythms on crates. Slaves used food crates as an alternative for drums because they were prohibited from having musical instruments. Using food crates as instruments was an effective way of keeping culture, tradition, and music alive.

Your **HANDS FREE** rhythm section for take-out!

BUNDLE NOW ALSO FOR LEFT FOOT AVAILABLE!



OSTBCJ-BU



OSTBCJ-L-BU

Our hands free percussion has "you", the stringed instrument player, in mind. Go busking in the streets, recording in a studio, jam with friends or write a song, adding percussive rhythm elements, all while playing your stringed instrument.

The ORTEGA STOMP BOX CAJON BUNDLES OSTBCJ-BU & OSTBJ-L-BU includes :



ORTEGA Cajon (with bundle only)
Size: 30 cm (11.75") W x 46 cm (18") H x 30 cm (11.75") D

Resonating body: Baltic Birch
Front plate OSTBJ-BU: Ammara wood
Front plate OSTBJ-L-BU: Baltic Birch (Golden Brown)

- 2 internal snare wires
- Adjustable front plate for more sound options
- Curved corners for more comfort
- Delivers full, rich tone
- Made in Europe



FREE Cajon backpack bag included!



ORTEGA CAJON PEDAL
OCJP-GB or OCJP-L-GB

- Heavy duty metal ground plate and metal pedal
- Soft foam beater (length adjustable)
- Cradle-like mount - fits all common Cajons
- Adjustable spring tension (pedal)



FREE Cajon pedal gig bag & drum key included!



Example right foot

TAP IT THE WAY YOU FEEL MOST COMFORTABLE!

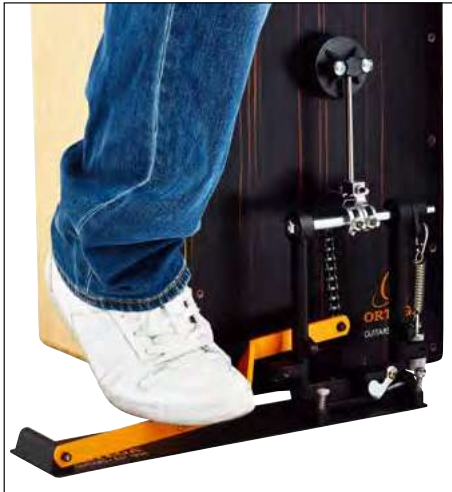

Your
**HANDS
FREE**
rhythm sections
for take-out!

CAJON PEDAL



OCJP-GB



LEFT FOOT

OCJP-L-GB



You already own a Cajon? The Ortega Percussion Cajon Pedal attaches firmly with yours. This pedal leaves your hands unrestricted to play along with your stringed instrument while keeping a steady kick drum rhythm beneath.

Create an infinite amount of grooves with your foot while your hands focus on playing guitar!

- Heavy duty metal ground plate and metal pedal
- Soft foam beater (length adjustable)
- Cradle-like mount - fits all common Cajons
- Adjustable spring tension (pedal)

FREE Cajon Pedal gig bag & drum key included!

GUITARIST FOOT TAMBOURINE



OGFT

The Guitarist Foot Tambourine is the perfect match for any stringed instrument player. This light and versatile "hands free" rhythm tool delivers a bright cutting tone, yet not overpowering. Easily mounted on your foot, it will go with any beat.

- Made from rubber wood in Ortega orange
- Bright, light accent for any stringed instrument
- Ergonomic design and hassle-free mounting
- 4 pairs stainless steel jingles

SINGER/SONGWRITER FOOT TAMBOURINE



OSSFT

The Singer/Songwriter Foot Tambourine is the perfect rhythm accessory for acoustic performances, studio applications or a fun jam sessions. The 5 pairs of stainless steel jingles deliver a precise, light shimmering sound. Small pocket friendly designed.

- Made from rubber wood in Ortega orange
- Bright, light accent for any stringed instrument
- Ergonomic design and hassle-free mounting
- 5 pairs stainless steel jingles



ORTEGA QUANTUMloop - MULTI DIGITAL PERCUSSION STOMP BOX & LOOPER

Choose between **16 DIFFERENT** BUILT-IN DRUM & PERCUSSION SAMPLED SOUNDS...

... PLUS ADD 4 CUSTOM SAMPLES (2 PER BANK) VIA USB.

20 AVAILABLE SAMPLED SOUNDS!

FREE ONLINE DOWNLOAD for sound import software (Mac & Windows)

BANK A		BANK B	
DRY KICK DRUM	SLAP CAJON	BALLAD SNARE	FINGER SNIP
FAT KICK DRUM	DOUMBK SLAP	SOUL SNARE	SHORT SHAKE
SWEET KICK DRUM	COWBELL	THE RIM	TAMBOURINE
80'S ELECTRO	PERSONAL 1	FOOT HIHAT	PERSONAL 1
DEEP CAJON	PERSONAL 2	THE CLAP	PERSONAL 2

QUANTUMloop

BUILT-IN LOOPER for instrument & sound banks

DIGITAL STOMP BOX & LOOPER with 16 built-in drum & percussion samples!

- 16 pre-installed sounds
- 4 empty slots for custom samples
- Built-in looper with unlimited numbers of overdubs
- Loop length: Up to 5 minutes
- Software for uploads & erase (free online download) - Mac & Windows
- Comfortable ergonomic design
- Solid mahogany wood housing
- Non-slip bottom coating & foot rest
- Bypass mode: True bypass
- IN & OUT 6.3 mm (1/4") jack - true discrete pass-through



CHANGE BETWEEN SOUNDS ON THE FLY. WITH 20 SAMPLES AND A LOOPER, YOUR POSSIBILITIES ARE ENDLESS.



- Removable foot rest (hook & loop)



- Trigger input, instrument in and seamless looper volume control



- Seamless volume control, Dynamic (velocity sensitivity) ON/OFF, instrument out (a true discrete pass-through) & USB port for sound import

QUANTUMexp



For maximum performance add the **QUANTUMexp** to your setup. Once connected with the QUANTUMloop via "trigger input" the sounds of BANK B are under the control of QUANTUMexp.

The QUANTUMexp operates "active" and includes a 9V battery.

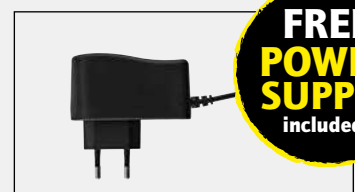

FREE POWER SUPPLY included!

- FREE 9V certified quality power supply included



STOMP BOX EFFECT SERIES



ORTEGA ANALOG STOMP BOX - PERFECT FOR PLAYERS ON THE GO & STREET PERFORMERS

The Ortega **ANNAlog** analog percussion stomp box is the perfect tool for guitarists, singer/songwriters and street performers wanting to add a percussive element to any performance. With it's analog design, no battery or power supply needed. Plug-In and ready. Detailed inner construction minimizes surrounding noise to maximize bass punch. Equipped with an input and output, our discrete pass through allows you to blend the percussive sound with your instrument signal to a single channel.



ANNAlog

ANALOG STOMP BOX with built-in sound optimized piezo technology.

- **No battery or power supply needed!**
- **Input & output - only one channel needed!**
- Comfortable ergonomic design for foot tapping
- Solid cherry wood housing
- Non-slip bottom coating
- Minimized surrounding noise
- Maximized bass punch
- Seamless volume control to adjust the level of bass punch (blend the percussion sound with the unaffected instrument signal together through the output to one channel)
- 6.3 mm (1/4") input jack (connect your guitar, bass or any other stringed instrument with a true discrete pass-through to output)
- 6.3 mm (1/4") output jack (connect to amp or sound system)

NO BATTERY
or
POWER SUPPLY
needed!

Your HANDS FREE
rhythm section
for take-out!

ORTEGA DIGITAL STOMP BOXES - PERFECT FOR SINGER/SONGWriters ON THE GO OR IN THE STUDIO

The Ortega **HORSE KICK V2** & **HORSE KICK PRO** digital stomp boxes are great tools for guitarists, singers, songwriters and street performers wanting to add a percussive element to any performance. With digital samples of real percussion sounds the HORSE KICK Stomp Boxes are way ahead of any existing analog/acoustic stomp boxes eliminating feedback and the surrounding noises. Just connect your favorite HORSE KICK to any amplifier or sound system and enhance your solo performance.

HORSE KICK V2

DIGITAL STOMP BOX with built-in digitally sampled "Cajon Bass" sound!

- Digital sample of a "Cajon Bass" sound - just tap your foot
 - Comfortable ergonomic design for foot tapping
 - Solid ash wood housing
 - Non-slip bottom coating
 - Velocity sensitive for an expressive experience
 - Seamless volume control to adjust percussion sound
 - 6.3 mm (1/4") input jack (connect your guitar, bass or any other stringed instrument with a true discrete pass-through to output)
 - 6.3 mm (1/4") output jack (connect to amp or sound system)
 - Powered by power supply
- FREE 9V certified quality power supply included**



Your **HANDS FREE** rhythm section for take-out!

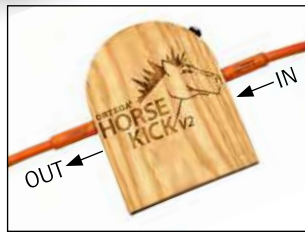

HORSE KICK PRO

DIGITAL STOMP BOX with multiple built-in digital samples of percussion sounds that can be played on its own, as a percussive instrument, or blended with your stringed instrument signal through the output.

- Digital samples of percussion instruments - just choose between 5 different percussion samples and tap your foot
- Comfortable ergonomic design for foot tapping
- Solid sapele (mahogany) wood housing
- Non-slip bottom coating
- Velocity sensitive for an expressive experience
- Seamless volume control to adjust percussion sounds (blend the percussion sound with the unaffected instrument signal together through the output to one channel)
- 6.3 mm (1/4") input jack (connect your guitar, bass or any other stringed instrument with a true discrete pass-through to output)
- 6.3 mm (1/4") output jack (connect to amp or sound system)
- Powered by 9V battery or power supply

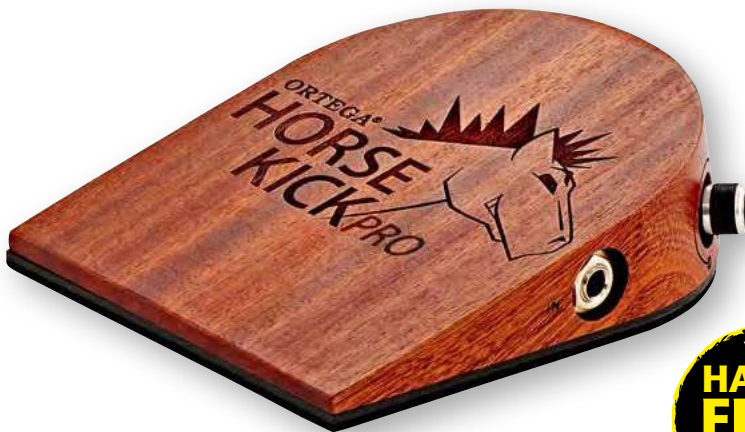

Your **HANDS FREE** rhythm section for take-out!

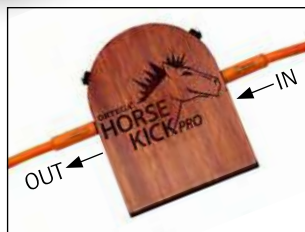

Choose between **5 DIFFERENT PERCUSSION SAMPLES:**

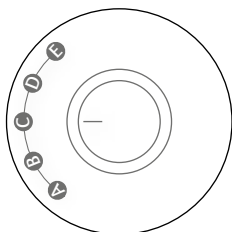
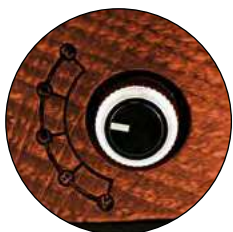

- E: Tambourine
- D: Cabasa
- C: Cowbell
- B: Kick Drum
- A: Cajon Bass

FREE 9V certified quality power supply included

FREE 9V battery already packed for you



ACCESSORIES



Index

Page

Stomp Boxes	004
Ukuleles & Guitarleles	010
Nylon String Guitars	042
★ The Private Room	092
Acoustic Basses	098
Banjos	112
Mandolins	120
Percussion	126

Accessories

134

Tuners	136
Cables & Power	138
Capos	140
Humidifiers & Care	141
Care & Cleaning	142
Useful Helpers	143
Tuning Machines	144
Strings	145
Picks & Strap Locks	146
Straps	148
Bags & Cases	150
Stands & Hangers	154
Apparel & Merchandise, POS	156



TUNERS

HEADSTOCK TUNER OCCT-1BK



OCCT-1BK



Blue backlight -
not in tune



Green backlight -
in tune

The OCCT-1BK is a clip-on tuner of the newest generation and comes packed with all the practical features needed:

- Sensitive sensor – tunes in noisy environment
- One-handed swivel clamp
- Large, easy-to-read 2-color display (blue/green)
- In tune – backlight illuminates green!
- Rubberized shock proof body
- Attractive 360 degree rotating design

FEATURES: Ukulele, bass, guitar, violin & chromatic pre-installed modi

COLOR: black

- Incl. battery (coin cell, TYPE CR2032)

HEADSTOCK TUNER GECCOTUNE



GECCOTUNE



360 degree rotation

Fully chromatic clip tuner, especially designed to attach on instrument's headstock rear.

Unique design – attaches easily to all guitar headstock shapes. Calibratable from 436–445 Hz. Discreet micro size. Unlimited viewing angles, 360 degree rotation.

Brightly lit accurate display. Fits guitars, basses, ukuleles, wind instruments and many more!

- Incl. battery (coin cell, TYPE CR2032)

HEADSTOCK TUNER OCAT-2BK



OCAT-2BK



Built-in VISUAL metronome

The clip-on multi talent: Tuner & metronome. Mic and vibe sensor built-in to use anywhere. Fully chromatic and calibratable (410–490 Hz). Flat tuning up to 4 semitones. Built-in VISUAL metronome.

- Incl. battery (coin cell, TYPE CR2032)

BATTERIES OER-CR-2032/2

2pack of 3V coin cell batteries, Type CR2032 (recommended for all Ortega ukulele preamps and tuners)



OER-CR-2032/2



Type CR2032



SEA DEVIL

PEDAL TUNER SEA DEVIL

LET THERE BE LIGHT... on your pedal board. The first pedal board tuner with USB connectable LED lights (included!)

PEDAL TUNER

- Tuning range: A0 (27.5 Hz) - C8 (4,186 Hz)
- Accuracy: +/- 1 cent
- Calibration: 436-445 Hz (1 Hz step)
- Flat modi: b, bb, bbb
- Fully chromatic
- Indicator: 39 seg FND & 1 LED
- Input: 6.3 mm (1/4") input jack & USB for light
- Output: 6.3 mm (1/4") output jack (true bypass)
- Power: 9V DC adapter (not included - ORTEGA OPS9500 recommended)
- Dimensions: 112 x 60 x 30 mm
- Weight: 250 g net.

USB LIGHTS (LED)

- Turn on automatically when connected to pedal tuner via USB port
- USB port - also perfect for charging cell phones, too



LED lights



USB port



Pedal tuner



OCTOPUS

PEDAL TUNER OCTOPUS

The new epicenter for pedalboards inside a "heavy duty" metallic housing.

Tuning mode: Fully chromatic tuner, 5 color LED display, easy to read in darkness. Sensitive & fast, sound muted in tuning mode

Power supply mode: DC 18V input, 6 x DC 9V/100 mA output, 2 x DC 9V/500 mA output, fully independent circuits, short circuit/overcurrent protection

Noiseless switching:

18V power supply, 8 x DC power cable & 1 x polarity reversal cable INCLUDED!



Power plant for 8 devices





CABLES / POWER

INSTRUMENT CABLES - ECONOMY SERIES

ORTEGA GUITARS Economy Series Instrument & Patch Cables offer quality design and sound for all live & studio environments. Reliable & durable, our cables are developed to last and deliver the best balance between performance and players' equipment.

- Custom designed with an extra thick O.D. (diameter) of 8 mm
- Extra thick braided nylon jacked avoids annoying "entangling" and minimizes handling noise
- 24 Gauge AWG (American Wire Gauge) with 95% OCC copper braided shielding for flexibility and minimize interference
- High grade industries connectors with heat shrunk sleeves for additional strain relief

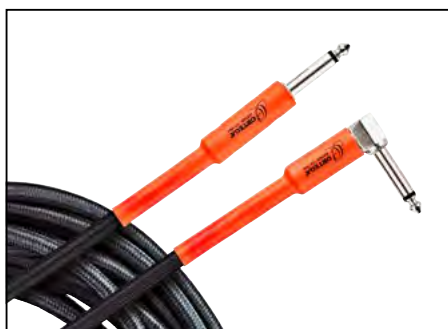

OECI-xx



OECIS-xx



OECPA3-06

INSTRUMENT CABLE STRAIGHT/ANGLE

OECI-5 5 ft (1,5 m), 1/4" (6,3 mm) jack/jack, 0.8 q, braided nylon over PVC, black

OECI-10 10 ft (3,0 m), 1/4" (6,3 mm) jack/jack, 0.8 q, braided nylon over PVC, black

OECI-15 15 ft (4,5 m), 1/4" (6,3 mm) jack/jack, 0.8 q, braided nylon over PVC, black

OECI-20 20 ft (6,0 m), 1/4" (6,3 mm) jack/jack, 0.8 q, braided nylon over PVC, black

OECI-30 30 ft (9,0 m), 1/4" (6,3 mm) jack/jack, 0.8 q, braided nylon over PVC, black

INSTRUMENT CABLE STRAIGHT/STRAIGHT

OECIS-5 5 ft (1,5 m), 1/4" (6,3 mm) jack/jack, 0.8 q, braided nylon over PVC, black

OECIS-10 10 ft (3,0 m), 1/4" (6,3 mm) jack/jack, 0.8 q, braided nylon over PVC, black

OECIS-15 15 ft (4,5 m), 1/4" (6,3 mm) jack/jack, 0.8 q, braided nylon over PVC, black

OECIS-20 20 ft (6,0 m), 1/4" (6,3 mm) jack/jack, 0.8 q, braided nylon over PVC, black

OECIS-30 30 ft (9,0 m), 1/4" (6,3 mm) jack/jack, 0.8 q, braided nylon over PVC, black

PATCH CABLE ANGLE/ANGLE

OECPA3-06 0.6 ft (18 cm), 1/4" (6,3 mm) jack/jack, 0.8 q, braided nylon over PVC, black, pack of 3

CABLE TIES PACK OF 10

Ortega Cable ties keep your cables coiled up and well organized for tidy storage. Works with all instrument, microphone and power cables.

OCBT-10

Cable ties, hook & loop 0.6 x 0.065 ft (18 cm x 2 cm), orange, pack of 10



OCBT-10



well organized

DC POWER SPLITTER CABLES



ODC4

ODC6

ODC8

The Ortega ODC4/ODC6/ODC8 are perfect to use with 9V & 18V power supplies. Feeds 4, 6 or 8 devices simultaneously.

ODC4 4head version,
1.40 m/4.6 ft cable length

ODC6 6head version,
2.00 m/6.5 ft cable length

ODC8 8head version,
2.70 m/8.9 ft cable length

CABLE LENGTH OF 3 METERS/9.8 FEET!

POWER SUPPLY



OPS9500EU
(most European countries)

OPS9500US
(USA & CANADA)

OPS9500JP
(JAPAN)

OPS9500UK
(Great Britain)

The **OPS9500** power supply series is intended for the use with any effect pedals (analog or digital) requiring 9V and good for up to 500 mA.

Special feature:

Cable length of 3 meters /9.8 feet!

- INPUT POWER 100-240 VAC, 50/60 Hz
- OUTPUT POWER 9V DC/500 mA

Ortega power supplies are CE (EUROPE) & UL/class6 (USA) & PSE (Japan) tested and certified.

BATTERIES OER-CR-2032/2



OER-CR-2032/2



Type CR2032

2pack of 3V coin cell batteries, Type CR2032 (recommended for all Ortega ukulele preamps and tuners)

Extra thick braided nylon jacked avoids annoying "entangling" and minimizes handling noise.





CAPOS



TWCAPO-CR



TWCAPO-SBK

2 IN 1
ONE CAPO
FOR CURVED + FLAT
FRETBOARDS



Flat



Curved

TWINCAPOS FLAT/CURVED

Ortega Guitars' brand new TWINcapo is not a one-trick-pony! It covers flat fretboards as well as curved fretboards. Available in satin black/orange & gloss chrome/black. The QUICK CHANGER between different fretboard shapes.

- High-grade alloy
- COVERS FLAT & CURVED/RADIUS FRETBOARDS
- Perfect silicone cushion
- Designed for acoustic guitars, classic guitars (up to 52 mm nut) & electric guitars

Available models:

TWCAPO-CR

Gloss chrome/black silicone cushion

TWCAPO-SBK

Satin black/orange silicone cushion



OCAPO-SBK



OCAPO-CR



OCAPOUKE-CR



SMCPAD-OR



CAPOS FLAT

Easily adjustable design made of aluminum alloy and silicone cushion.

OCAPO-SBK

Satin black, FLAT fretboard up to 52 mm nut width

OCAPO-CR

Chrome, FLAT fretboard up to 52 mm nut width

OCAPOUKE-CR

Chrome, perfect for Ukulele and Banjo

Made of aluminum alloy the new "SPIDER MONKEY" Capos allow micro adjustment for exact tension. Together with a perfect silicone cushion the need to retune the instrument is be drastically reduced.

SMCPAD-OR

Designed for FLAT (classical) fretboards, up to 52 mm width at nut!



OCAPOCV-SBK



OCAPOCV-CR



SMCPADCV-SBK

CAPOS CURVED

Easily adjustable design made of aluminum alloy and silicone cushion.

OCAPOCV-SBK

Satin black, CURVED (radius) fretboard up to 52 mm nut width

OCAPOCV-CR

Chrome, CURVED (radius) fretboard up to 52 mm nut width

Made of aluminum alloy the new "SPIDER MONKEY" Capos allow micro adjustment for exact tension. Together with a perfect silicone cushion the need to retune the instrument is be drastically reduced.

SMCPADCV-SBK

Designed for CURVED (radius) fretboards, up to 52 mm width at nut!



HUMIGT-BK



HUMIGT-SV



HUMIUK-BK



HUMIUK-SV



Suspend between the strings - no body touch

HUMIDIFIERS

Humidifying wooden acoustic instruments is the most underrated topic but the lack of humidification is the number one cause of repairs. The ORTEGA humidifiers are the most easy and simple way to maintain your instruments in best humidity condition.

- Ortega humidifiers suspend between the strings and never touch any part of the instruments body
- Easy to refill sponge style system
- Non-drip design - releases moisture (if needed for instrument) evenly and slowly to maintain the proper humidity level
- Includes a syringe for water

Available models :

HUMIGT-BK Sound hole humidifier for acoustic guitar - black

HUMIGT-SV Sound hole humidifier for acoustic guitar - silver

HUMIUK-BK Sound hole humidifier for ukulele, 1/4 & 1/2 size instruments - black

HUMIUK-SV Sound hole humidifier for ukulele, 1/4 & 1/2 size instruments - silver



HUMIBUSTER100
HUMIBUSTER80



Includes a syringe for water refill

HUMIBUSTER

Feedback killer & Humidifying system. Permanent feedback cover for acoustic instruments with the additional function of a humidifying system. Equipped with a sponge and pores the system maintains the relative humidity of your instrument and protects the wood from drying out.

HUMIBUSTER100
100 mm (4") diameter, fits most acoustic guitars and acoustic basses

HUMIBUSTER80
85 mm (3.35") diameter, fits most classical guitars

PROTECTION FOILS



OERP



OBCF



Electrostatic reusable foils. The perfect protection against dings & scratches. Clear transparent. To use on gloss finishes only. Removable any time!

OERP
Pickguard for top, transparent

OBCF
Back cover foil, transparent



CARE & CLEANING



OWPSC-EB
OWPTB-EB



OWPSC-FMA
OWPTB-FMA



OWPSC-WN
OWPTB-WN



Diameter example



Choose your personal style

PICKGUARDS UKULELE

Wooden ukulele pickguards

EBONY - FLAMED MAPLE - WALNUT

Made from REAL wood, the Ortega ukulele pickguards light up your instrument and makes you special. Easy to put on with already installed adhesive foil. Shaped for Soprano, Concert, Tenor & Baritone size.

EBONY

OWPSC-EB Soprano & Concert sound hole diameter appx. 55 mm

OWPTB-EB Tenor & Baritone sound hole diameter appx. 58 mm

FLAMED MAPLE

OWPSC-FMA Soprano & Concert sound hole diameter appx. 55 mm

OWPTB-FMA Tenor & Baritone sound hole diameter appx. 58 mm

WALNUT

OWPSC-WN Soprano & Concert sound hole diameter appx. 55 mm

OWPTB-WN Tenor & Baritone sound hole diameter appx. 58 mm

FRETBOARD OIL OLEM



OLEM

Lemon oil – cleaning, conditioning & restoring
The original Ortega Guitars Lemon Oil is perfect to remove dirt, wax and grease from dark wooden surfaces incl. unfinished fretboards.*

60 ml (2.1 fluid oz)

* For best results we recommend you use original Ortega polish cloth OPC-GR/LG, OPC-LY/LB or OPC-XXL

CLEANER OGC1



OGC1

Original Ortega guitar cleaner, made in Germany.
pH neutral with a decent cedar note. Perfect for gloss, open pore and satin finish (do not use for French polish).

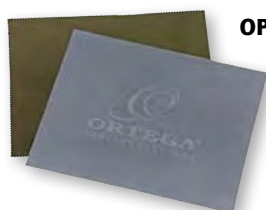

OPC-GR/LG

PACK OF 2!



OPC-LY/LB

PACK OF 2!



OPC-XXL

EXTRA LARGE!

POLISH CLOTH

Professional, extra soft microfiber polishing/cleaning cloth with serrated edge. Features embossed Ortega logo.

OPC-GR/LG – pack of 2! (green/light grey)
Dimensions: 29 cm x 24 cm (11.5" x 9.5")

OPC-LY/LB – pack of 2!
(light yellow/light brown)

Dimensions: 29 cm x 24 cm (11.5" x 9.5")

OPC-XXL – extra large size (light yellow)
Dimensions: 50 cm x 40 cm (19.70" x 15.75")



FEX4



FEX5



Only a few minutes for best results



Lockable pistons for more exercise possibilities



FINGER TRAINER

The original Ortega Guitars FEX4 & FEX5 are advanced pocked-sized, light weight training tools for different needs. FEX4 & FEX5 helps you to build-up strength for the entire hand and forearm.

Adjustable tension for each finger

FEX4 3-7 lbs (appx. 1.3-3.2 kg), 4 pistons

FEX5 3-8,5 lbs (appx. 1.3-3.9 kg), 5 lockable pistons for more training possibilities.

Train and maintain strength for your fingers, palm and forearms, supports reaction speed, flexibility and other high difficult action training.

PERFECT PRE-GIG WARM-UP TOOL, PRE-CLIMBING EXERCISE TOOL / SPORTS SUPPORT & MEDICAL REHABILITATION TOOL.*

FEX4 individual adjustable tension for 4 available pistons

FEX5 individual adjustable tension for 5 available pistons

* Ask your doctor IN ADVANCE for medical rehabilitation use.

CABLE TIES PACK OF 10



OCBT-10



Ortega Cable ties keep your cables coiled up and well organized for tidy storage. Works with all instrument, microphone and power cables.

OCBT-10
Cable ties, hook & loop
0.6 x 0.065 ft
(18 cm x 2 cm), orange,
pack of 10

STRING WINDER



OSW-STD



VE40-OSW-STD

String replacement in a few seconds with this classic string winder. The notched head removes bridge pins quickly and safely. Perfect shaped for nylon string & acoustic guitars.

OSW-STD
Classic string winder, single

VE40-OSW-STD
Useful display box - filled with 40x OSW-STD

ELIMINATOR



ELIMINATOR100
ELIMINATOR86



FITS ALMOST ALL ACOUSTIC INSTRUMENTS!

Feedback Eliminator/Soundhole Cover
Simply place the ELIMINATOR into your acoustics' soundhole and start your feedback-free performance. Designed to play at a far greater volume on stage without the risk of unwanted howling or feedback. Safe for the instruments' finish due to its soft rubber.

ELIMINATOR100
100 mm (4") diameter,
fits most steel strings & acoustic basses

ELIMINATOR86
86 mm (3.38") diameter,
fits most nylon & classical guitars



TUNING MACHINES

PIMP YOUR NYLON STRING WITH STYLE

TUNING MACHINES OTMSTD-GOWH



OTMSTD-GOWH

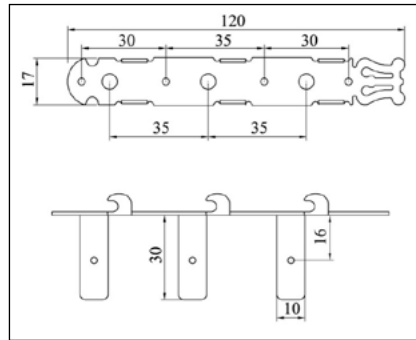

RATIO: 1:14

Golden lyra-design tuning machines with white nylon rollers and white pearl buttons



OTMDLX-GOBK



OTMDLX-BKBK

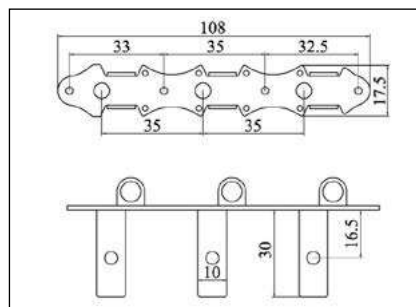
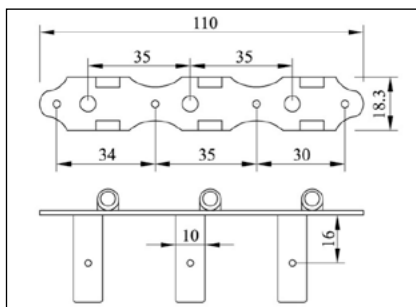

TUNING MACHINES

OTMDLX-GOBK

RATIO: 1:14

Golden baseplate tuning machines with black nylon rollers and black ebony-style buttons

OTMDLX-BKBK

RATIO: 1:14

Black baseplate tuning machines with black nylon rollers and black ebony-style buttons

TUNING MACHINES OTMPRIVATE



OTMPRIVATE

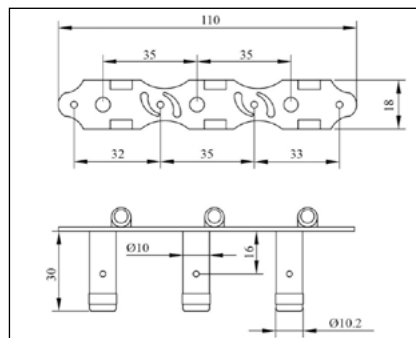

RATIO: 1:18

Brushed brass baseplate tuning machines with plated steel worm shafts, black nylon rollers and black ebony-style buttons

TUNING MACHINES OTMPREMIUM



OTMPREMIUM

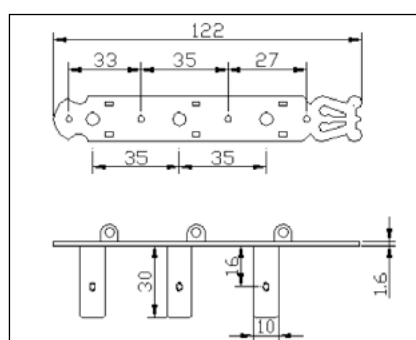

RATIO: 1:18

Brushed brass Lyra-design baseplate tuning machines with black plated steel worm shafts, black nylon rollers, pearl inlays and black acrylic-style buttons.

4STRING UKULELE



ORTEGA GUITARS white nylon series ukulele strings are developed in cooperation with the world famous ukulele string maker AQUILA/Italy. The combination of materials used are designed to deliver the perfect combination of warm yet punchy tone.

SOPRANO:
art. **UWNY-SO** .026 / .037 / .032 / .024
CONCERT:
art. **UWNY-CC** .027 / .038 / .032 / .024
TENOR:
art. **UWNY-TE** .028 / .038 / .032 / .026
BARITONE:
art. **UWNY-BA** w / w / .032 / .027

8STRING NYLON GUITAR OCTA-8NS



OCTA-8NS

8string nylon string guitar set - MADE IN GERMANY Custom made of the finest materials, with great precision and HANDCRAFTED by expert hands. Optimized for 690 mm scale. E/B/E/A/d silver plated copper wound on nylon silk / nylon modified on nylon silk g/b/e - nylon rectified. 029/.032/.041/.031/.037/.046/.060/.083

5STRING BANJO RHSM-5



RHSM-5

Rüdiger Helbig Signature 5string banjo set. MADE IN USA .010, .012, .014, .022nw, .010 PLUS EXTRA FREE .010

4STRING ACOUSTIC BASS ODW-4



ODW-4

Custom made in Germany for short scale acoustic basses (up to 25"), D-Walker standard set! Silver plated copper wound on nylon silk. .043/.059/.071/.080 fully balanced strings 5.5 kg (12.12 Lbs) Custom developed for D-Walker bass!

STRING WINDER



OSW-STD



VE40-OSW-STD

String replacement in a few seconds with this classic string winder. The notched head removes bridge pins quickly and safely. Perfect shaped for nylon string & acoustic guitars.

OSW-STD
Classic string winder, single
VE40-OSW-STD
Useful display box - filled with 40x OSW-STD



PICKS & STRAP LOCKS

UKULELE/NYLON STRING PICKS UKEPICK-ASS



UKEPICK-ASS

PERFECT FOR ANY NYLON STRING GUITAR, TOO!

Soft and extra large REAL LEATHER PICKS – especially designed for ukulele players but also perfect to use with any Nylon String Guitar.

- Warm soft tones with no loss of volume
- Assorted pack of 3 black/white/red



OGP-BP
OGP-WP
OGP-TO

PICKS

Guitar picks – Made in Germany. Produced with highest industry standard – pack of 10

OGP-TO-T10

tortoise, thin

OGP-TO-M10

tortoise, medium

OGP-TO-H10

tortoise, heavy

OGP-WP-T10

white pearl, thin

OGP-WP-M10

white pearl, medium

OGP-WP-H10

white pearl, heavy

OGP-BP-T10

blue pearl, thin

OGP-BP-M10

blue pearl, medium

OGP-BP-H10

blue pearl, heavy

20 PICKS – packing unit



PU20-OGPOR-M

Ortega PU20-OGPOR-M packing unit (PU) contains 20 pieces of original guitar picks in Ortega orange featuring a 0.71mm, medium thickness for a great and handy playability. A light “sandy” surface serves a comfortable grip.

STRAP LOCK



OSLOPRO-CR



OSLOPRO-GB



OSLOPRO-GO

STRAP LOCK – PRO VERSION

incl. one extra FREE pair of screws/pins

2 INSTRUMENTS – only ONE system needed! Safety first! Connects guitar/bass strap safely with the instrument. Includes 2 strap locks, felt washers, nuts and 2x2 strap pins/screws

OSLOPRO-CR

Chrome, bright incl. FREE 2nd pair of screws/pins

OSLOPRO-GB

Gloss black incl. FREE 2nd pair of screws/pins

OSLOPRO-GO

Gold, bright incl. FREE 2nd pair of screws/pins





STRAPS



ONS50STD-BK

ONS50STD-BR

ONS50STD-WH

ONS50STD-RD

ONS50STD-BL

NYLON STRAPS – UNICOLOR



50 mm (1.97") width, leather ends with embossed Logo, up to 1800 mm (70.86") length:

ONS50STD-BK

"black"

ONS50STD-BR

"brown"

ONS50STD-WH

"white"

ONS50STD-RD

"red"

ONS50STD-BL

"blue"



OSN-50OGT

OSN-50EVO

OSN-50EGY

OSN-50COR

OSN-50BUB

NYLON STRAPS



50 mm (1.97") width, leather ends, up to 1420 mm (55.9") length:

OSN-50OGT

"ortegaguitars"

OSN-50EVO

"evolution"

OSN-50EGY

"egypt"

OSN-50COR

"corn circuit"

OSN-50BUB

"bubbles"



OSS2-BK

OSS2-BR

OSS2-HO

SUEDE LEATHER STRAPS



Soft and smooth suede leather, 65 mm (2.56") width, up to 1420 mm (55.9") length:

OSS2-BK

"black", O-signet embroidered

OSS2-BR

"brown", O-signet embroidered

OSS2-HO

"honey", O-signet embroidered



OSL2-85BK

extra wide

OSL2-85BR

extra wide

GENUINE LEATHER STRAPS



Genuine leather, up to 1420 mm (55.9") length:

OSL2-85BK

85 mm (3.35") extra wide, black, perfect for bass

OSL2-85BR

85 mm (3.35") extra wide, brown, perfect for bass

NYLON UKULELE STRAPS



OUS-GRFL

OUS-MAY

OUS-ORFL

OUS-PALM

OUS-PUFL

OUS-SUN

OUS-VOO



Special "slim" nylon uke straps, leather ends, 37 mm (1.54") width, up to 1350 mm (53.15") length:

- OUS-GRFL**
"green flower"
- OUS-MAY**
"maya"
- OUS-ORFL**
"orange flower"
- OUS-PALM**
"palm island"
- OUS-PUFL**
"purple flower"
- OUS-SUN**
"sundown"
- OUS-VOO**
"voodoo"

NYLON UKULELE STRAPS - HOOK



OUSHK-BK

OUSHK-BR

OUSHK-WH

OUSHK-RD

OUSHK-BL



Special "slim" nylon uke strap with soundhole hook. 37 mm (1.54") width at upper part, up to 700 mm (27.56") length:

- OUSHK-BK**
"black"
- OUSHK-BR**
"brown"
- OUSHK-WH**
"white"
- OUSHK-RD**
"red"
- OUSHK-BL**
"blue"

MANDOLIN STRAPS



OSM-BK

OSM-BR



OSMDLX-BK

OSMDLX-BR

Leather, up to 1700 mm (66.92") length:

- OSM-BK**
standard, black
- OSM-BR**
standard, brown
- OSMDLX-BK**
deluxe, padded shoulder, black
- OSMDLX-BR**
deluxe, padded shoulder, brown

BANJO STRAPS



OBJS-BK

OBJSDLX-BK

60 mm (2.36") width, up to 1300 mm (51.18") length:

- OBJS-BK**
banjo strap standard, genuine/suede leather, carabiner (2x)
- OBJSDLX-BK**
banjo strap deluxe, genuine/suede leather, padded carabiner (2x)



BAGS ECONOMY

GUITAR BAGS ECONOMY OGBSTD-xx

Professional guitar bags - priced user friendly. Made from sturdy nylon material with a 10 mm soft inside padding and heavy duty zippers. Includes a big accessory compartment (perfect size for music books) and two adjustable shoulder straps.



OGBSTD-xx

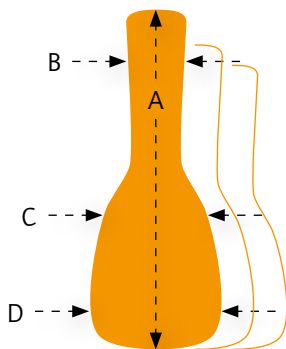

DIMENSIONS				
	A	B	C	D
OGBSTD-44	105.0 cm 41.34"	14.0 cm 5.52"	32.0 cm 12.6"	40.0 cm 15.75"
OGBSTD-34	98.0 cm 38.58"	14.0 cm 5.52"	30.0 cm 11.8"	37.0 cm 14.56"
OGBSTD-12	96.0 cm 37.8"	14.0 cm 5.52"	30.0 cm 11.8"	35.0 cm 13.78"

UKULELE BAGS ECONOMY OUBSTD-xx

Professional ukulele bags - priced user friendly. Made from sturdy nylon material with a 10 mm soft inside padding. Includes an accessory compartment (fits an ORTEGA OUPS portable uke stand!) and two adjustable shoulder straps.



OUBSTD-xx

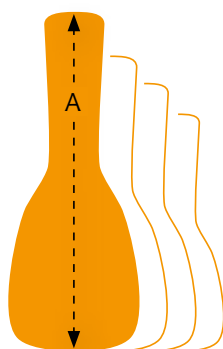

DIMENSIONS	
	A (inside)
OUBSTD-SO soprano length	55.0 cm 21.65"
OUBSTD-CC concert length	62.0 cm 24.41"
OUBSTD-PINE concert length	62.0 cm 24.41"
OUBSTD-TE tenor length	68.0 cm 26.77"
OUBSTD-BA baritone length	78.0 cm 30.71"

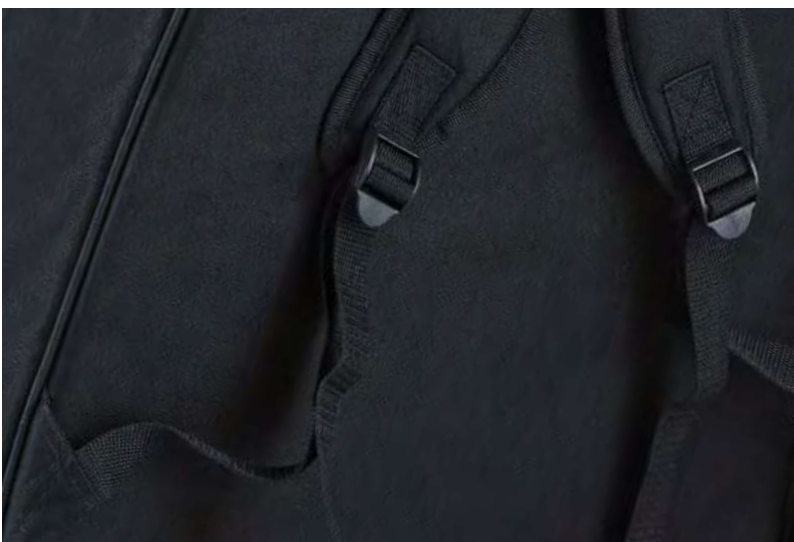
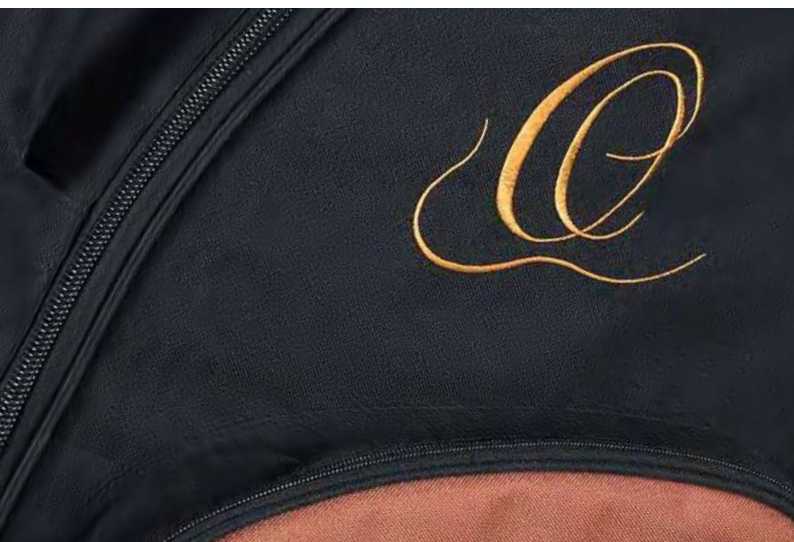

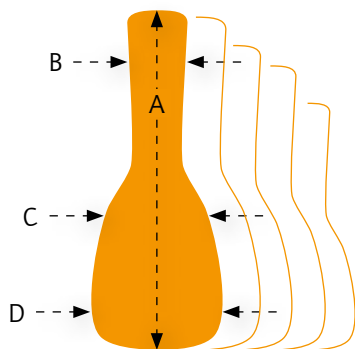

GUITAR BAGS PRO ONB-xx

Professional classic gig bags made from heavy duty nylon material. Thick padding inside, very wide neck brace which safety locks, heavy duty zippers, wide and comfortable shoulder straps (adjustable), padded handle and two accessory compartments distinguishes this exclusive bag.

DIMENSIONS				
	A	B	C	D
ONB44L full size extra long	105.4 cm 41.5"	14.3 cm 5.63"	31.12 cm 12.25"	40.0 cm 15.75"
ONB44 full size	103.5 cm 40.75"	14.3 cm 5.63"	30.5 cm 12.01"	37.15 cm 14.63"
ONB34 three quarter size	94.62 cm 37.25"	14.3 cm 5.63"	26.7 cm 10.51"	35.88 cm 14.13"
ONB12 half size	88.27 cm 34.75"	14.3 cm 5.63"	23.5 cm 9.25"	32.7 cm 12.87"
ONB14 quarter size	76.84 cm 30.25"	14.3 cm 5.63"	21.6 cm 8.5"	28.25 cm 11.12"

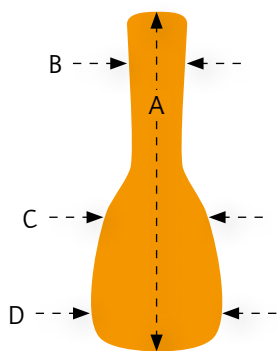

BASS BAG PRO OABB

Professional acoustic bass gig bag made from heavy duty nylon material. Thick padding inside, very wide neck brace which safety lock, heavy duty zippers, wide and comfortable shoulder straps (adjustable), padded handle and two accessory compartments distinguishes this exclusive bag. Works for up to 34" longscale.

DIMENSIONS				
	A	B	C	D
OABB	125.0 cm 49.2"	19.0 cm 7.48"	38.0 cm 14.96"	46.0 cm 18.11"

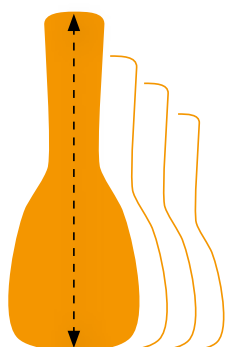

UKULELE BAGS PRO OUGB-xx

Professional ukulele gig bags made from heavy duty nylon material. Thick padding inside, heavy duty zippers, padded handle and an accessory compartment distinguishes this exclusive bag.

DIMENSIONS	
	A (inside)
OUGB-SO soprano length	55.0 cm 21.65"
OUGB-CC concert length	62.0 cm 24.41"
OUGB-TE tenor length	68.0 cm 26.77"
OUGB-BA baritone length	78.0 cm 30.71"



CASES ECONOMY

CASES ECONOMY

The industry standard instrument cases in classic black vinyl finish – priced user friendly. Flat top, 15 mm padding – covered by „coffee“ velvet, accessory compartment, chrome hardware and a strong handle distinguishes these timeless cases.



OCCSTD

OCCSTD-T

OCCSTD-DN

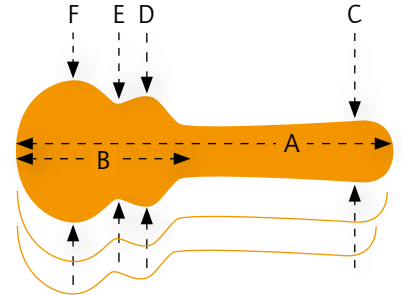

GUITAR CASES DIMENSIONS

	A	B	C	D	E	F	Height
OCCSTD regular classic	103.0 cm 40.55"	56.0 cm 22.05"	14.5 cm 5.71"	27.5 cm 10.83"	26.0 cm 10.24"	38.5 cm 15.16"	12.0 cm 4.72"
OCCSTD-T thinline classic	107.0 cm 42.13"	56.0 cm 22.05"	14.5 cm 5.71"	27.5 cm 10.83"	26.0 cm 10.24"	38.5 cm 15.16"	10.5 cm 4.13"
OCCSTD-DN dreadnought	107.5 cm 42.32"	58.0 cm 22.83"	15.5 cm 6.1"	29.5 cm 11.61"	28.0 cm 11.02"	41.0 cm 16.14"	13.5 cm 5.31"



OABCSTD

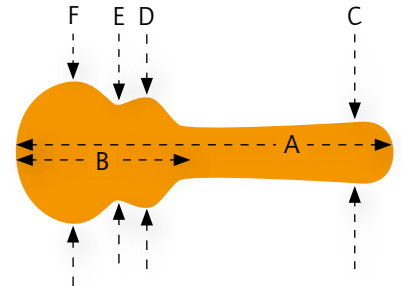

BASS CASE DIMENSIONS

	A	B	C	D	E	F	Height
OABCSTD acoustic bass	127.0 cm 50.0"	58.5 cm 23.03"	16.0 cm 6.3"	32.0 cm 12.6"	29.5 cm 11.61"	43.0 cm 16.93"	13.5 cm 5.31"



OMCSTD-A

OMCSTD-F

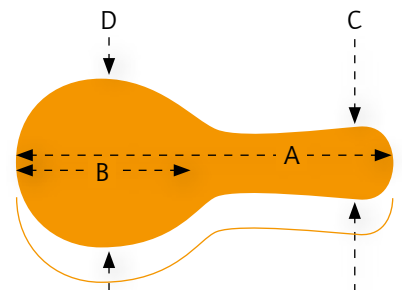

MANDOLIN CASES DIMENSIONS

	A	B	C	D	Height
OMCSTD-A A-style	71.0 cm 27.95"	39.0 cm 15.35"	15.0 cm 5.91"	27.5 cm 10.83"	10.0 cm 3.94"
OMCSTD-F F-style	71.0 cm 27.95"	39.0 cm 15.35"	15.0 cm 5.91"	27.5 cm 10.83"	10.0 cm 3.94"



OBJSTD

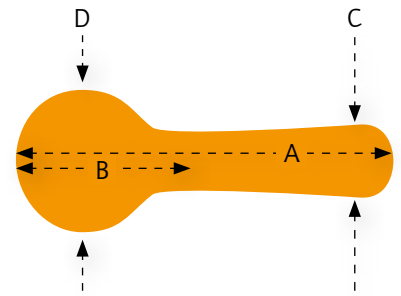

BANJO CASE		A	B	C	D	Height
DIMENSIONS						
OBJSTD	regular 5/6 String	103.0 cm 40.55"	44.0 cm 17.32"	14.0 cm 5.51"	34.5 cm 13.58"	12.5 cm 4.92"



OUCSTD-SO

OUCSTD-CC

OUCSTD-TE

OUCSTD-BA

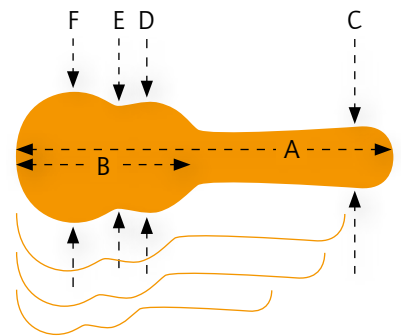

UKULELE CASES		A	B	C	D	E	F	Height
DIMENSIONS								
OUCSTD-SO	soprano	55.0 cm 21.65"	29.0 cm 11.42"	12.0 cm 4.72"	14.5 cm 5.71"	14.0 cm 5.51"	17.0 cm 6.69"	8.5 cm 3.35"
OUCSTD-CC	concert	66.5 cm 26.18"	32.5 cm 12.8"	13.0 cm 5.12"	14.5 cm 5.71"	14.0 cm 5.51"	19.5 cm 7.68"	9.0 cm 3.54"
OUCSTD-TE	tenor	71.0 cm 27.95"	37.0 cm 14.57"	13.5 cm 5.31"	18.5 cm 7.28"	16.5 cm 6.5"	22.0 cm 8.66"	10.0 cm 3.94"
OUCSTD-BA	baritone	81.0 cm 31.89"	40.5 cm 15.94"	16.5 cm 6.5"	21.0 cm 8.27"	18.0 cm 7.09"	25.0 cm 9.84"	10.0 cm 3.94"



CASES PRO



OCCPRO

OCCPRO-T

The extraordinary deluxe instrument cases in modern brown croco style vinyl finish. Arched case top, 15 mm padding – covered by „coffee crushed“ velvet, built-in hygrometer, generous accessory compartment, combination lock, bronze vintage style hardware and a comfortable soft double pipe handle disdinguishes these exclusive cases.

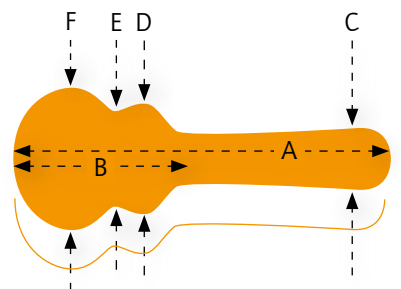

GUITAR CASES		A	B	C	D	E	F	Height
DIMENSIONS								
OCCPRO	regular classic	103.0 cm 40.55"	56.0 cm 22.05"	14.5 cm 5.71"	27.5 cm 10.83"	26.0 cm 10.24"	38.5 cm 15.16"	12.0 cm 4.72"
OCCPRO-T	thinline classic	107.0 cm 42.13"	56.0 cm 22.05"	14.5 cm 5.71"	27.5 cm 10.83"	26.0 cm 10.24"	38.5 cm 15.16"	10.5 cm 4.13"



STANDS & HANGERS

WALL HANGER

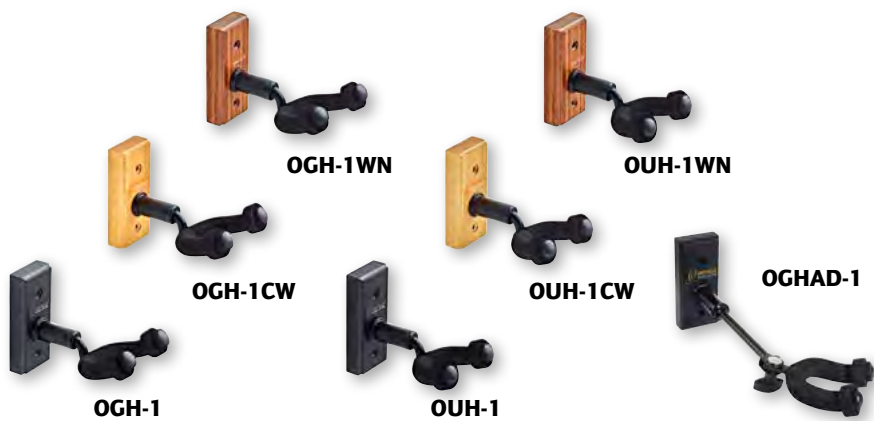

Easy to mount with included screws and drywall anchors. Soft padded cradle support.

Guitar/Bass wall hanger, straight

- OGH-1** Wood base, black
- OGH-1CW** Cherry wood base, natural
- OGH-1WN** Walnut wood base, natural

Ukulele wall hanger, straight

- OUH-1** Wood base, black
- OUH-1CW** Cherry wood base, natural
- OUH-1WN** Walnut wood base, natural

Guitar/Bass wall hanger, angle

- OGHAD-1** Wood base, black - adjustable angle

HOLDER OMUH-BK



OMUH-BK



Ukulele holder for microphone, guitar and music stands.

Holder easily clips onto stand. Fits all size ukuleles as well as mandolins or other small folk instruments. Extra strong clamp system and soft padded cradle support.

Color: all black

GUITAR STAND OGS-1BK



OGS-1BK



Ortega guitar stand, black/orange.

The perfect rest for acoustic guitars, acoustic basses, electric guitars and electric basses.

- Lightweight and durable steel tubing covered with soft black neoprene rubber tubing to protect your instrument. Folds down for easy transport and storage

- Security strap/neck included

(do not use with nitrocellulose-finished instruments)

WOODEN GUITAR/UKULE STANDS



The perfect stand for home, office and shop. Made from birch the Ortega guitar stand becomes your eye-catcher and supports the value of your beloved instrument. Soft and safe "anti-slip" padding for best protection. Assembled in minutes.

OWGS-1/OWUS-1

birch, dark brown

OWGS-2/OWUS-2

birch, natural bright

PORTABLE GUITAR/UKULE STANDS



Made with extremely lightweight and strong synthetic material. Fits all sizes of guitars, basses, ukuleles, mandolins & more. Divided body rest for electric or acoustic guitars (OPGS) and easy to fold.

4 HAND GRIPS AND YOU'RE DONE!

- 1-2-3-4 Fits your instrument
- 4-3-2-1 Fits your gig bag

- GUITAR:** **OPGS-1BK**
full black
- OPGS-1ORBK**
Ortega orange/black
- UKULELE:** **OPUS-1BK**
full black
- OPUS-1ORBK**
Ortega orange/black

1-2-3-4: FITS YOUR INSTRUMENT!

4-3-2-1: FITS YOUR GIG BAG!

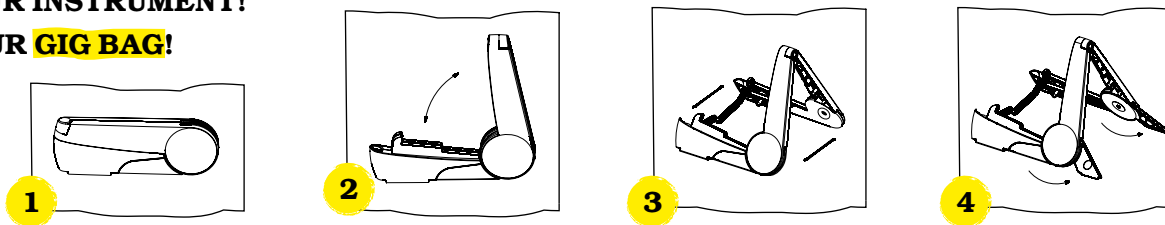

OMS-1BK

MUSIC STAND OMS-1BK

The Ortega portable music stand for the traveling musician or student on the go. Easy to use with 3 seamless tubes for adjusting height, a strong tripod base and a large book tray.

FREE bag included.

- Made of lightweight, non-corrosive aluminum
- Height adjustable from 57 cm (22") to 127 cm (50")
- Book tray: 43.5 cm (17.13") x 22 cm (8.66")



OWFS-1WR

OWFS-1NT

FOOT STOOL

Ortega headstock shaped wooden foot stool

- OWFS-1WR**
wine red
- OWFS-1NT**
natural



APPAREL & MERCHANDISE

THE 2018 COLLECTION - ORTEGA GUITARS ORIGINAL HEAD & BODY APPAREL

Trendy, fashioned and even fits you with a business suit. All tees & hoodies are available in M, L and XL, headware: one size fits all.

HEADWARE

BEANIE



OBEAN-BK

CAP



OCAP-BK



TEES

SKULL

Skull tee, available in black, charcoal and burgundy red



OSKULL-CO



OSKULL-BU



OSKULL-BK

OBAR-CO



OSIGN-BP



BARS

Bars tee, available in charcoal and burgundy red



OBAR-BU

SIGNATURE

Signature tee, available in ice grey and blueprint



OSIGN-IC

HEADSTOCK

Guitar head tee, available in black and charcoal

Bass head tee, available in black and charcoal



OHEAD-BK



OHEAD-CO



OBHEAD-BK

UKULELE

Ukulele flower tee, available in black and yellow



OFLOW-BK

Ukulele hang loose tee, available in black



OHANG-BK



OBHEAD-CO



OFLOW-YE

MERCHANDISE

HOODIE

Skull hoodie/sweater, available in black



OGSKULL-BK



OMUG-XL
Ortega coffee mug, 350 ml



ORT-MPAD
Ortega mousepad



ORT-LANYARD
Ortega lanyard



MERCHANDISE & POS



SW-W120-MA



Instruments not included



DIS-ORUKE-10 Ortega ukulele display fits 10 ukuleles from soprano to bariton/ukubass size

SW-W120-MA Ortega point of sale display modular system, 250 cm (98,43") height, 120 cm (47,24") width

OBS30V2 Bar/stage stool 76 cm (30")

OBS24V2 Bar/stage stool 61 cm (24")

ORUG Ortega shop/stage rug 140 x 80 cm (55" x 32") anti slip rubber bottom



OBS30V2

76 cm (30")



OBS24V2

61 cm (24")



DIS-ORUKE-10
Instruments not included

ORUG
140 x 80 cm (55" x 32")

WWW.ORTEGAGUITARS.COM
INFO@ORTEGAGUITARS.COM



WE VALUE BRAND PARTNERSHIP

Since establishing Ortega guitars in 1994, we've strived to find the best brands in supplying the important parts needed to complete our instruments. We value these relationships with our partners who match the quality and passion that we have for our instruments. Ortega guitars are equipped with the premium strings, hardware and electronics from the best brands.



ORTEGA® MagusUke

ORTEGA® MagusUkebass

ORTEGA® MagusPro

ORTEGA® MagusPro Bass

FISHMAN®

BAND®

ORTEGA GUITARS
CUSTOM MADE STRINGS

D'Addario

SAVAREZ

Aquila®
Le corde armoniche

All listed trademarks, brandnames and original logos are property of the registered owners.

Ortega Imprint

Due to CITES regulations and production related circumstances some specification changes become effective as a "running change" during 1st quarter 2018. Additional changes without notice possible. If necessary - dealer/distributor contact is recommended for detailed information.

Not responsible for typographic errors. No part of this brochure may be reprinted, reproduced or included in any online service or in any other form, in whole or in part, without the prior permission of Ortega. Specifications are subject to change without notice.

Content & Direction:

Bastian Krämer & Ortega Guitars team
Germany/USA - ortegaguitars.com

Concept, Design & Realization:

Werner Stubenvoll & zeitstopp team - zeitstopp.com

Web Design: tollwerk.de/ortegaguitars.com

Photography and Image Processing:

Christian Habermeier,
Sebastian Jäger - studio waldeck

Stock footage: istockphoto.com



This brochure has been printed on certified paper sourced from sustainably managed forests.

O-CA121712



Ortega
Musik-Meinel-Str.1
91468 Gutenstetten
Germany

info@ortegaguitars.com
www.ortegaguitars.com

